

The phylogeny and taxonomy of Hippopotamidae (Mammalia: Artiodactyla): a review based on morphology and cladistic analysis

JEAN-RENAUD BOISSERIE^{1,2*}

¹Laboratoire de Géobiologie, Biochronologie et Paléontologie Humaine, UMR CNRS 6046, Université de Poitiers, 40 avenue du Recteur, Pineau 86022 Cedex, France

²Laboratory for Human Evolutionary Studies, Department of Integrative Biology, Museum of Vertebrate Zoology, University of California at Berkeley, 3101 Valley Life Science Building, Berkeley, CA 94720-3160, USA

Received August 2003; accepted for publication June 2004

The phylogeny and taxonomy of the whole family Hippopotamidae is in need of reconsideration, the present confusion obstructing palaeoecology and palaeobiogeography studies of these Neogene mammals. The revision of the Hippopotamidae initiated here deals with the last 8 Myr of African and Asian species. The first thorough cladistic analysis of the family is presented here. The outcome of this analysis, including 37 morphological characters coded for 15 extant and fossil taxa, as well as non-coded features of mandibular morphology, was used to reconstruct broad outlines of hippo phylogeny. Distinct lineages within the paraphyletic genus *Hexaprotodon* are recognized and characterized. In order to harmonize taxonomy and phylogeny, two new genera are created. The genus name *Choeropsis* is re-validated for the extant Liberian hippo. The nomen *Hexaprotodon* is restricted to the fossil lineage mostly known in Asia, but also including at least one African species. The genus *Hippopotamus* is confirmed. These changes represent substantial advances for understanding the evolutionary history of the Hippopotamidae, and provide a new framework for future studies. © 2005 The Linnean Society of London, *Zoological Journal of the Linnean Society*, 2005, 143, 1–26.

ADDITIONAL KEYWORDS: Africa – Asia – extant – fossil – Miocene – Pleistocene – Pliocene – systematics.

INTRODUCTION

The roots of the family Hippopotamidae were most probably in Africa during the middle Miocene (Coryndon, 1978; Pickford, 1983). Although this family is now restricted to that continent, Hippopotamidae has extended toward Eurasia on several occasions since the late Miocene (Kahlke, 1990). During the Mio-Pliocene, Hippopotamidae diversified and became very abundant in African ecosystems. Their remains are among the most frequent mammals found in various palaeontological sites (Coryndon, 1971; Gèze, 1985; Harris, Brown & Leakey, 1988; Pavlakis, 1990; Harris, 1991; Faure, 1994; Leakey *et al.*, 1996; Harrison, 1997; Alemseged, 1998; Brunet *et al.*, 1998; Vignaud *et al.*, 2002). The apparent success of these mammals may be

linked to their unusual semiaquatic way of life. Indeed, their current association with continental waters is probably ancient and may be primitive. Moreover, the mammals thought to be related to the Hippopotamidae show several adaptations to aquatic environments. The putative stem-group to Hippopotamidae is generally thought to be the family Anthracotheriidae (Colbert, 1935; Coryndon, 1978; Gentry & Hooker, 1988), for which an amphibious way of life was proposed on the basis of taphonomic (Pickford, 1983, 1991; Ducrocq, 1997) and morphological (F. Lihoreau, pers. comm.) evidence. Moreover, many studies based on molecular data (e.g. Gatesy, 1998; Ursing & Arnason, 1998; Nikaido, Rooney & Okada, 1999) indicate that Cetacea form the extant sister group of the Hippopotamidae. Recent fossil evidence and morphological studies tend to agree with this hypothesis (Gingerich *et al.*, 2001; Naylor & Adams, 2001; Thewissen *et al.*, 2001).

*E-mail: jbrmail@uclink.berkeley.edu

In regard to their abundance, diversity, ecology and evolutionary trends (Gèze, 1985; Harris, 1991; Weston, 1997), the Hippopotamidae potentially constitute an important data source for palaeobiogeographical and palaeoenvironmental reconstructions. However, the Hippopotamidae are generally not included in such studies for the Mio-Plio-Pleistocene of Africa and Eurasia, notably because their phylogeny is still highly contestable (Harris, 1991; Harrison, 1997; Gentry, 1999; Weston, 2000). Such a revision is a long-term project, in regard to the c. 40 species known for the last 15 Myr and the thousands of specimens disseminated in many museums. The aim of this paper is to initiate this work: the main clades within the Hippopotamidae (excluding the enigmatic and poorly known *Kenyapotamus* from the Miocene of Kenya; see Pickford, 1983) are deciphered by means of a morphological study.

Currently, the genus *Hexaprotodon* Falconer & Cautley, 1836 (abbreviated *Hex.*) includes most of the African and Asian fossil species, a few European Miocene species, as well as the extant Liberian hippo [*Hex. liberiensis* (Morton, 1844)]. This study relies essentially on the best-known species of this genus, together with some African species of the genus *Hippopotamus* Linnaeus, 1758. It is based on a large sample of recent and fossil material, including several recently described Pliocene hippos from Chad and Ethiopia (Boisserie *et al.*, 2003; Boisserie & White, in press), and, for the first time, on a formal cladistic analysis.

PREVIOUS CONCEPTS OF HIPPO PHYLOGENY AND TAXONOMY

Historically, three genera have been employed for fossil and extant hippo species. The genus *Hippopotamus* (abbreviated *Hip.*) was created for the only known hippo during the 18th century: the extant common hippo *Hip. amphibius*, which is distinguished by four incisors (tetraprotodont). Subsequently, *Hexaprotodon* was proposed as a subgenus (Falconer & Cautley, 1836) for Siwalik (India/Pakistan) Mio-Pliocene hippos having six incisors. Owen (1845) elevated *Hexaprotodon* to genus rank. Finally, in regard to its peculiar morphology, Leidy (1853) attributed the genus name *Choeropsis* to the extant diprotodont Liberian hippo, initially described by Morton (1844) as *Hip. liberiensis*.

These genera have been intensely discussed in subsequent literature. The discrimination of *Hexaprotodon* (Asian hippos) and *Hippopotamus* (Afro-European hippos) on the basis of incisor number was shown to be inadequate (Lydekker, 1884). Nevertheless, Colbert (1935) recognized the distinctness of *Hexaprotodon* in many cranial features, notably on the

basis of bone contacts and their shapes in the lachrymal area. In a major work on hippos, Hooijer (1950) recognized that the Asian hippos form a distinct lineage, but preferred to use only the name *Hippopotamus* for the following reason (Hooijer, 1950: 33): 'I prefer not to split the genus *Hippopotamus* because this would leave us a certain number of as yet unsatisfactorily identifiable forms from Europe and Africa which certainly do not belong to *Hippopotamus s.s.* with *Hip. amphibius* as the genotype and for which the creation of new generic names then would be inevitable'. However, studying the East African fossil hippos, Coryndon (1967, 1977, 1978) decided to place most of the fossil African and Asian hippos in the genus *Hexaprotodon*, defined mainly on the absence of contact between the lachrymal and the nasal bones. This position was strongly contested by Stuenes (1989), who revealed that the Madagascan hippos (*Hip. madagascariensis* and *Hip. lemerlei*), once thought closely related, exhibit, respectively, *Hexaprotodon* and *Hippopotamus* features, as well as important intraspecific variation in the lachrymal area. With some minor reservations, Stuenes (1989) agreed with Pickford (1983) in including all fossil hippos in *Hippopotamus*. Most recent authors (Harris, 1991; Harrison, 1997; Weston, 1997, 2000, 2003; Gentry, 1999; van der Made, 1999; see also Fig. 1) admit that *Hexaprotodon (sensu Coryndon, 1977)* is based on plesiomorphic features and is likely paraphyletic, but have maintained the distinct use of *Hippopotamus* and *Hexaprotodon* awaiting a revision of hippo phylogeny. For Harris (1991), these two genera could be seen as two different 'ecological grades' of the same unique lineage. He recommended workers 'to retain these generic names for purposes of communication' (Harris, 1991: 57).

As with *Hexaprotodon*, the genus *Choeropsis* has been alternatively criticized or validated in the literature. Currently, some authors (e.g. Harris, 1991; Weston, 1997, 2000, 2003; Gentry, 1999) follow Coryndon (1977) in considering the Liberian hippo a *Hexaprotodon* species on the basis of its lachrymal area morphology, while others (Pickford, 1983; Harrison, 1997) agree with Arambourg (1947) that the mix of primitive and derived features of this animal indicates that it belongs to a distinct lineage, and thus supports a differentiation at the generic level.

MATERIAL

One of the main obstacles to a correct assessment of hippo phylogeny is intraspecific skeletal variability, already pointed out for the recent and fossil species (Hooijer, 1950; Coryndon, 1970; Weston, 1997). In order to estimate the possible variation range for each character, a large sample of recent crania (about 200

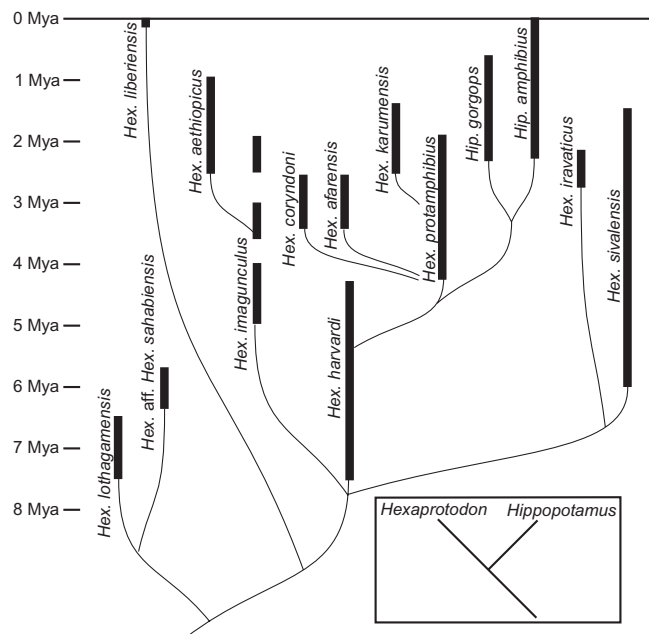

Figure 1. Synthesis of recent phylogenies (Harrison, 1997; Weston, 2000) for the family Hippopotamidae. The genus *Hexaprotodon* is shown to be paraphyletic, and *Hippopotamus* being related to the derived species *Hex. protamphibius*. The important position of *Hex. harvardi* and the early divergence of the *Hex. liberiensis* lineage can be also noted.

Hip. amphibius and 40 *Hex. liberiensis* from several European museums) has been examined.

Table 1 shows a list of the main fossil taxa considered in this paper. More than 400 well-preserved specimens (more or less complete skulls, mandibles and dental rows) have been examined. These specimens are principally housed in the following institutions: Centre National d'Appui à la Recherche (CNAR), N'Djaména, Tchad; National Museum of Ethiopia (NME), Addis Ababa, Ethiopia; National Museums of Kenya (NMK), Nairobi, Kenya; and the Natural History Museum (NHM), London, UK. Three new forms have been included in this work. Two are from the Chad Lower Pliocene sites (*Hex. mingoz* and *Hex. cf. mingoz*, described in Boissérie *et al.*, 2003). The other is from the Plio-Pleistocene Bouri Formation, in the Middle Awash Valley, Afar region, Ethiopia (*Hex. bruneti*, described in Boissérie & White, 2004).

Some of the taxa listed in Table 1 merit additional comments. First, the material noted here as *Hexaprotodon* sp. from Myanmar, housed in the NHM, could be related to *Hex. iravaticus* Falconer & Cautley, 1847, as known from Upper Pliocene deposits of Myanmar (Colbert, 1938). However, the lectotype of this species (no. 14771 in the NHM) has been rejected from this study. Indeed, this partial symphysis is obviously derived from a juvenile individual: it shows a right P/2 that is far from being fully erupted. In the recent *Hip. amphibius* and in *Hex. liberiensis*, this situation is observed in individuals that still retain a juvenile

morphology. A good illustration of this can be seen in the study of Laws (1968), wherein 20 age groups are defined on the basis of stages of tooth replacement and wear. In term of Laws' age groups, specimen 14771 could be attributed to groups V to VII, which correspond to individuals with canine processes absent or only poorly developed. In a fully adult mandible from Myanmar, housed also in the NHM (specimen no. M8361), these processes are appreciably laterally extended. Therefore, the term 'narrow muzzled' that Gentry (1999) applied to this species could be ill-founded, and the lectotype should not be informative in this important regard. The mandible M8361 and some associated teeth are the only material referred to here as *Hexaprotodon* sp. from Myanmar.

Hooijer (1950) interpreted the species *Hex. palaeindicus* (from Narbada beds, central India; Lydekker, 1884) as a subspecies of *Hex. sivalensis*. Given the important morphological differences between the NHM specimens referred to these taxa, and considering the theoretical difficulties related to fossil subspecies, for this work, I choose to conserve the specific definition of this Narbada material. The species *Hex. namadicus*, also known from specimens from the Narbada beds, is here considered as a possible forerunner of *Hex. palaeindicus*, following Lydekker (1884) and Hooijer (1950).

The material noted in Table 1 as 'small hippopotamids' from the Western Rift has various origins. In the NHM, it includes: several teeth and a braincase (no.

Table 1. Fossil taxa examined and references consulted in this study. Geographical distribution: ^a, Ethiopia; ^b, Kenya; ^c, India; ^d, United Arab Emirates; ^e, Pakistan; ^f, Uganda; ^g, Chad. Temporal distribution: Mio., Miocene; Ple., Pleistocene; Pli., Pliocene; L., Late; M., Middle; U., Upper

Taxa	Main occurrences	Other references
<i>Hex. aethiopicus</i> (Coryndon & Coppens, 1975)	Turkana basin, ^{a,b} (U. Pli.–L. Ple.)	Coryndon, 1976; Gèze, 1980; Harris, 1991
<i>Hex. corydoni</i> Gèze, 1985	Hadar, ^a (M. & U. Pli.)	Gèze, 1980
<i>Hex. harvardi</i> Coryndon, 1977	Lothagam, ^b (U. Mio. – L. Pli.)	Weston, 1997, 2003
<i>Hex. karumensis</i> Coryndon, 1977	Turkana basin, ^{a,b} (U. Pli. – L. Ple.)	Harris, 1991
<i>Hex. lothagamensis</i> Weston, 2000	Lothagam, ^b (U. Mio. – L. Pli.)	Weston, 1997, 2003
<i>Hex. palaeindicus</i> (Falconer & Cautley, 1847)	Narbada beds, ^c (Ple.)	Lydekker, 1884; Colbert, 1935; Hooijer, 1950
<i>Hex. protamphibius</i> (Arambourg, 1944)	Turkana basin, ^{a,b} (L. Pli. – U. Pli.)	Arambourg, 1947; Coryndon, 1976; Gèze, 1980, 1985; Harris <i>et al.</i> , 1988; Harris, 1991
<i>Hex. cf. protamphibius</i>	Kanapoi, ^b (L. Pli.)	Weston, 1997, 2003
<i>Hex. aff. sahabiensis</i>	Abu Dhabi, ^d (U. Mio.)	Gentry, 1999
<i>Hex. sivalensis</i> Falconer & Cautley, 1836	Siwaliks, ^{e,e} (U. Mio – M. Ple.)	Lydekker, 1884; Colbert, 1935; Hooijer, 1950
<i>Hexaprotodon</i> sp.	Myanmar (U. Pli.)	Colbert, 1935, 1938; Hooijer, 1950; see also Gentry, 1999 on age
Small hippopotamids	Western Rift, ^{b,f} (U. Mio. – L. Ple.)	Misonne, 1952; Cooke & Coryndon, 1970; Erdbrink & Krommenhoek, 1975; Pavlakis, 1990; Faure, 1994
<i>Hip. gorgorps</i> Dietrich, 1928	Olduvai, ^f ; Turkana basin, ^{a,b} (U. Pli. – M. Ple.)	Coryndon, 1971; Harris, 1991
<i>Trilobophorus afarensis</i> Gèze, 1985	Hadar, ^a (M. & U. Pli.)	Gèze, 1980
<i>Hex. mingoz</i>	Kollé, ^g (L. Pli.)	Boisserie <i>et al.</i> , 2003
<i>Hex. cf. mingoz</i>	Kossom Bougoudi, ^g (U. Mio – L. Pli.)	Boisserie <i>et al.</i> , 2003
<i>Hex. bruneti</i>	Bouri, ^a (U. Pli.)	Boisserie & White, 2004

M26336, described in Cooke & Coryndon, 1970) collected in the Kaiso Formation (Uganda); a partial skull (no. M14801, described and figured in Cooke & Coryndon, 1970) from the Kazinga Channel (Uganda); a fragmentary mandible (no. M15939, cited in Kent, 1942; Ditchfield *et al.*, 1999), from Rawi (Homa Peninsula, Kenya); and some fragmentary tooth remains from the N'Kondo Formation (Uganda). Considering the heterogeneous origins of this material, and its overall fragmentary condition, these fossils are not incorporated in the cladistic analysis; but the affinities of some specimens are discussed in regard to the results of this analysis.

The positions of several other examined forms (*Hex. lothagamensis*, *Hex. aff. sahabiensis*, *Hex. corydoni*, *Hex. sp.* from Myanmar) are not inferred from the cladistic analysis because only mandibles are known.

CLADISTIC ANALYSIS

OUTGROUP

The choice of an outgroup for this analysis was difficult because the actual sister group of the Hippopotami-

dae is not known with certainty. Several hypotheses have been proposed in the literature: the Anthracotheriidae (Falconer & Cautley, 1847; Lydekker, 1884; Colbert, 1935; Coryndon, 1978; Gaziry, 1987; Gentry & Hooker, 1988); the Eo-Oligocene Cebochoeridae (Pearson, 1927); the Suidae (Matthew, 1929; O'Leary & Geisler, 1999; Thewissen *et al.*, 2001); or other suiform artiodactyls (Geisler, 2001). More recently, the Tayassuidae have been also proposed as stem group for the Hippopotamidae (Pickford, 1983). However, by comparison to the primitive hippo braincase, the Suidae and Tayassuidae show basi-cranial morphologies that seem much too derived to play a role in the ancestry of the relatively recent Hippopotamidae. Cebochoeridae seem to be more closely related to Choeropotamidae (Gentry & Hooker, 1988; in concordance with the systematics adopted by Sudre, 1978). Although a complete review of this question is still needed, the artiodactyl phylogeny of Gentry & Hooker (1988) is followed here: these authors linked the Hippopotamidae to the Anthracotheriidae.

Within the Anthracotheriidae, the phylogeny is also far from being clear. A primitive form is preferred here, because the choice of a derived form would

require an extensive evaluation of the relationships within this family and with the Hippopotamidae. Among the primitive anthracotheres, a preference for more or less complete material considerably restricts the possibilities. Coombs & Coombs (1977) described *Anthracokeryx* Pilgrim & Cotter, 1916 as the sister group of all the 'fully evolved' anthracotheres. In contrast to the other primitive anthracothere genera, *Anthracokeryx* is well documented. Indeed, a crushed but complete skull is known from Pondaung (upper Middle Eocene of Myanmar; Holroyd & Ciochon, 1994) and has been attributed to *Anthracokeryx ulnifer* Pilgrim (1928) by Colbert (1938). In this analysis, *A. ulnifer* is taken as an outgroup.

CHARACTERS

The 37 adult cranial and dental features are described in the Appendix. No postcranial features are used because of the uncertainty of postcranial bone identifications at the species level (Weston, 1997) and the lack of detailed studies of this part of the hippo fossil record (Stuenes, 1989). As a convention, state 0 is the state observed in *Anthracokeryx ulnifer*. The multi-state characters are unordered. In the character illustrations (Figs 2–5), the character numbers are followed

by the figured state number enclosed between parentheses. The various figures are not at identical scales.

RESULTS

The matrix (Table 2) includes 37 characters and 15 taxa, with a missing data percentage of 7.4%. The analysis was performed in PAUP* v.4.0β10 (Swofford, 1998), with the branch-and-bound search option on unordered and unweighted characters. All characters appeared to be informative. Three equally parsimonious phylogenetic trees were obtained, with a length of 81 steps, a consistency index CI = 0.6420 and a retention index RI = 0.7752. The strict consensus of these trees is given with the results of a bootstrap analysis (1000 replicates) for an estimate of the node robustness (Fig. 6). The second of the three most parsimonious trees (Fig. 7) shows the character state changes for each node (ACCTRAN option). The following discussion is based on these figures.

Hex. liberiensis & Pliocene Chadian hippopotamids clade (node 12)

This clade is the sister group of all the other Hippopotamidae analysed. In literature, *Hex. liberiensis* has

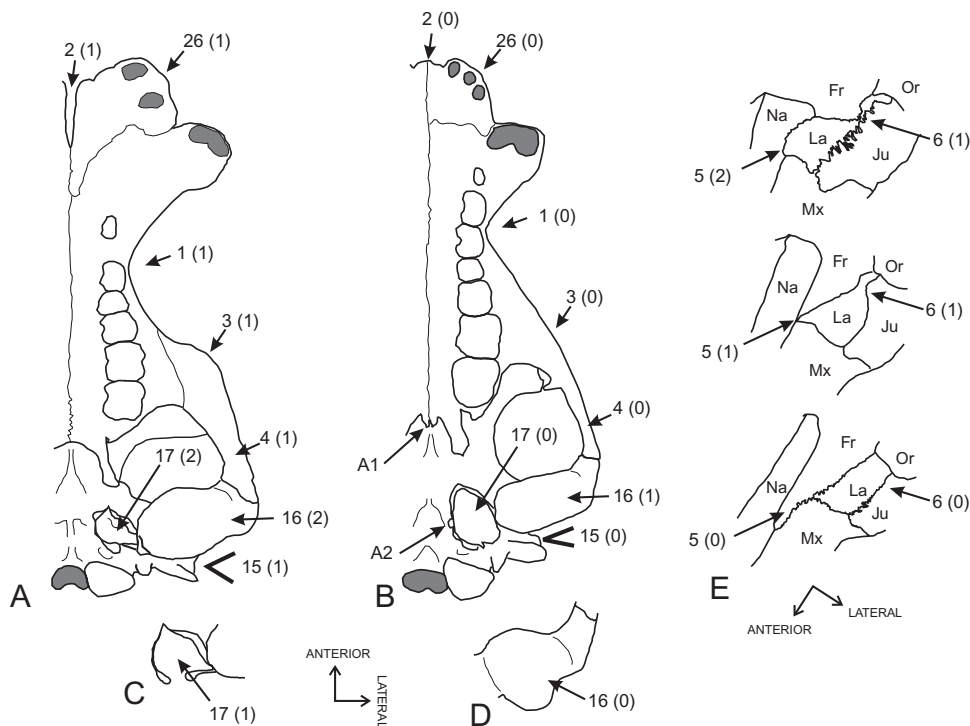

Figure 2. Cranial character states. A, ventral view of a *Hippopotamus amphibius* skull. B, ventral view of a *Hexaprotodon liberiensis* skull. C, Schematic view of *Hex. harvardi* tympanic bulla area. D, Schematic view of *A. ulnifer* glenoid articular area. E, Three dorsal views of different bone contacts in the lachrymal area (from bottom to top: in *Hex. harvardi*, in *Hex. protamphibius*, in *Hip. amphibius*). A1 and A2 are *Hex. liberiensis* autapomorphies (see text).

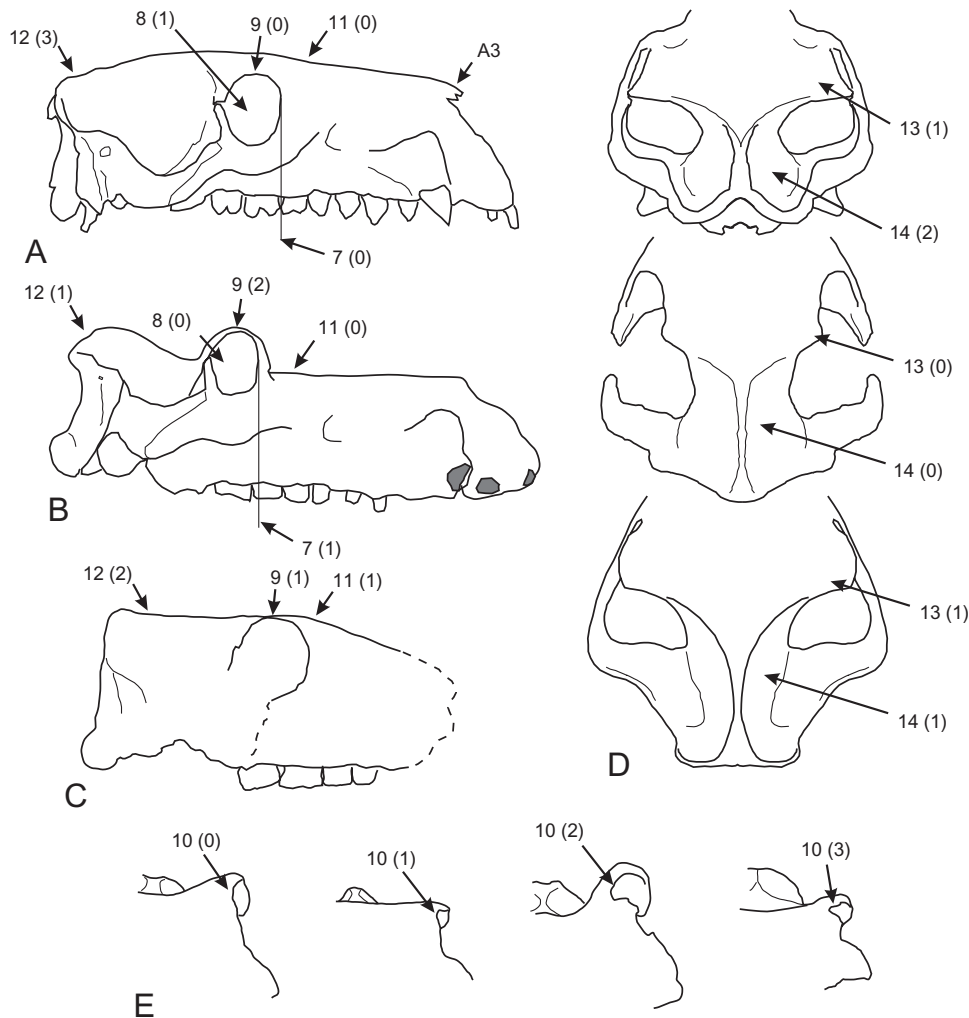

Figure 3. Cranial character states. A, lateral view of a *Hexaprotodon liberiensis* skull. B, Lateral view of a *Hippopotamus amphibius* skull. C, lateral view of a *Hex. mingo* skull. D, three dorsal views of the braincase (from bottom to top: in *Hex. harvardi*, in *Hex. mingo*, in *Hip. amphibius*). E, four schematic anterior views of the left orbit (from right to left: in *Hex. protamphibius*, in *Hex. harvardi*, in *Hip. gorgops*, in *Hex. sivalensis*).

frequently been considered more primitive than the other extant and fossil species (cf. Fig. 1). Weston (2000) indicated that only *Hex. lothagamensis*, its related form from Abu Dhabi (*Hex. aff. sahabiensis* in Gentry, 1999) and *Hex. crusafonti* could be more primitive than the extant Liberian hippo. Although not included in the cladistic analysis, the affinities of those hippopotamids are discussed below. Regardless, the antiquity of the *Hex. liberiensis* lineage is confirmed here. Its close relationship with the new Chadian hippopotamids is important because the fossil record was up to now thought to lack closely related forms for the Liberian hippo. However, this affinity must be envisaged cautiously. Only one synapomorphy unifies these taxa: the great size of the orbit (character 8, state 1). This feature, with a possible strong adap-

tive value, could be convergent. The three other character states that support this clade are homoplastic (character 18, state 1; character 25, state 1; character 28, state 1). As a result, this clade is only weakly supported. In fact, it could be interpreted as one or several lineages mainly differentiated from the rest of the Hippopotamidae by retaining numerous skull plesiomorphies.

Remarks: The Pliocene Chadian hippopotamids exhibit no differences in the characters used in this analysis. Their distinction is essentially based on some biometrical differences (see Boisserie *et al.*, 2003). For these two forms, the validation or invalidation of a specific separation should be possible with the discovery of more complete material of *Hex. cf.*

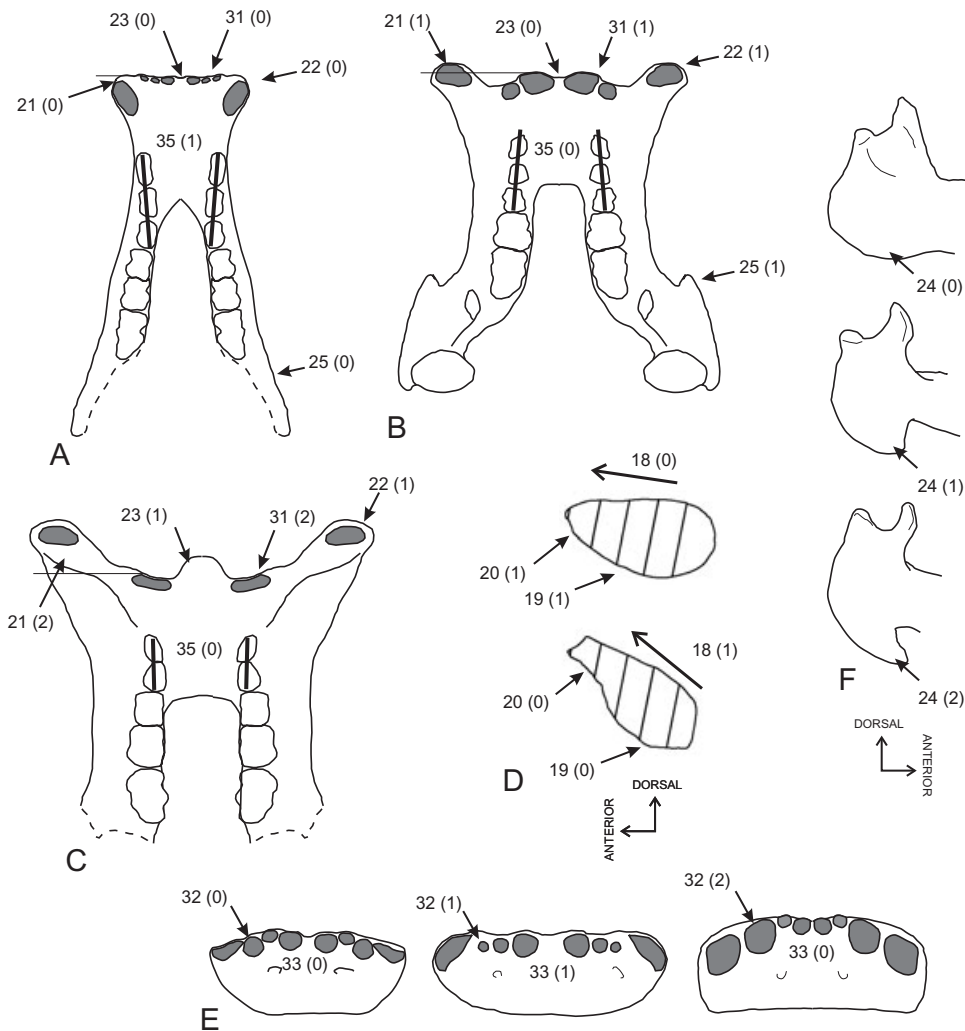

Figure 4. Mandibular character states. A, dorsal view of *Hexaprotodon* aff. *sahabiensis* mandible. B, dorsal view of *Hippopotamus amphibius* mandible. C, dorsal view of *Hex. karumensis* mandible. D, sagittal cross section (at the I/1-I/1 diastema) of the symphysis (bottom: in *Hex. sivalensis*, top: in *Hip. amphibius*); E, three schematic anterior views of the symphysis (from left to right: in *Hex. mingozi*, in some *Hex. protamphibius*, in *Hex. bruneti*). F, three schematic lateral views of the vertical ramus (from bottom to top: in *Hip. amphibius*, in *Hex. sivalensis*, in *Anthracokeryx ulnifer*).

mingozi from c. 5-Myr-old strata of Kossom Bougoudi (Chad).

Hex. harvardi, Asian & East-African hippopotamids & *Hippopotamus* clade (nodes 2 & 3)

In comparison to the clade discussed below, nodes 2 and 3 are marked by the acquisition of, respectively, four and five apomorphic states of the skull morphology. Some of these apomorphies characterize more advanced hippo anatomy, as seen in *Hip. amphibius*. At node 2, these are the posterior orbit (character 7, state 1) with a deep notch of the anterior border (character 10, states 2–3) and a strong supra-orbital process (character 13, state 1). At node 3 (excluding

Hex. harvardi), these are the deep constriction of the muzzle (character 1, state 1), the facial tubercle (character 3, state 1), the elevated sagittal crest (character 12, state 1) and the small compressed tympanic bulla (character 17, state 2). The numerous plesiomorphies of *Hex. harvardi* have been widely cited (Coryndon, 1976, 1977; Gèze, 1980; Harrison, 1997; Weston, 1997, 2003). Its position in this cladogram does not disagree with recently proposed phylogenies (cf. Fig. 1 and, particularly, Harrison, 1997).

Asian hippopotamids clade (node 10)

Only one apomorphy supports this clade: the narrow deep notch of the anterior border of the orbit (charac-

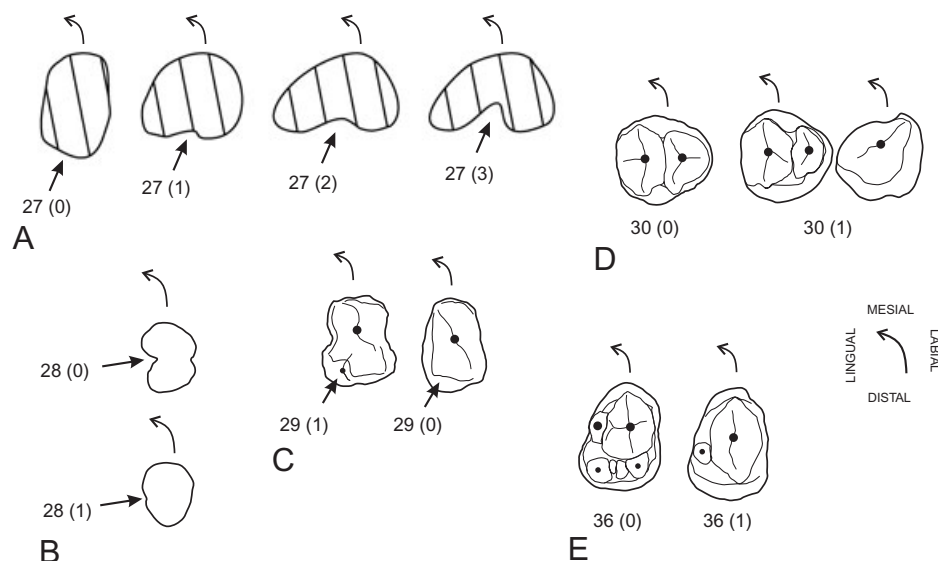

Figure 5. Dental character states. A, upper canine cross section (from left to right: in *Anthracokeryx ulnifer*, in *Hippopotamus amphibius*, in *Hexaprotodon bruneti*, in *Hex. harvardi*). B, outline of the P1/alveolus (bottom: in *Hex. protamphibius*, top: in *Hex. sivalensis*). C, occlusal view of the P3/ (left: in *Hex. bruneti*, right: in *Hex. protamphibius*). D, occlusal view of the P4/ (left: in *Hex. harvardi*, right: both in *Hex. protamphibius*). E, occlusal view of the P4/ (left: in *Hex. mingo*, right: in *Hex. aethiopicus*).

Table 2. Character matrix. Missing data are indicated by ‘?’

Characters	11111		11112		22222		22223		33333		33
Taxa	12345	67890	12345	67890	12345	67890	12345	67890	12345	67	
<i>Anthracokeryx ulnifer</i>	00000	00000	00000	00000	00000	00000	00000	00000	00000	00	
<i>Hex. mingo</i>	01000	00110	12000	11110	00011	03110	00001	00			
<i>Hex. cf. mingo</i>	??000	0?110	12000	11110	00011	03?10	00001	00			
<i>Hex. bruneti</i>	1????	?????	???1?	??110	100?1	?2001	02001	00			
<i>Hex. harvardi</i>	00000	01011	02110	11010	00010	03010	00001	00			
<i>Hex. cf. protamphibius</i>	1?110	01011	02110	12011	00111	03101	00001	00			
<i>Hex. protamphibius</i>	11111	11020	01121	22001	11121	13101	11101	00			
<i>Hex. karumensis</i>	11111	11020	01121	22011	211?1	13101	21100	00			
<i>Hex. aethiopicus</i>	1??1?	?1020	0?121	2?111	11121	13101	11101	10			
<i>Hex. sivalensis</i>	10110	01023	01110	12110	00011	03001	00001	10			
<i>Hex. palaeindicus</i>	??110	01023	01110	22110	000?1	????1	02001	?1			
<i>Hex. afarensis</i>	11112	11011	0111?	12011	00021	021?1	01001	00			
<i>Hip. amphibius</i>	11112	11022	01121	22001	11021	11101	11010	11			
<i>Hip. gorgops</i>	11112	11022	01121	22001	21021	11101	11010	11			
<i>Hex. liberiensis</i>	00000	00100	03000	10110	00111	13101	21?01	10			

ter 10, state 3). The two other state changes at the node are convergences (characters 9 and 18). This clade includes the two Indian species (*Hex. sivalensis* and *Hex. palaeindicus*) with the Ethiopian *Hex. bruneti* (Boissier & White, 2004). On the basis of its anatomical features and biometrical measurements, these authors linked this 2.5-Myr-old East African species with the Asian hippopotamids, and then considered it as an Asian migrant. This species forms a

clade with *Hex. palaeindicus* only on the basis of I/3 stronger than I/1 (character 32, state 2). Owing to the paucity of data, ambiguity persists at node 11 for the state changes in character 16 and 27 (their position here results from the selected ACCTRAN option).

East-African and Hippopotamus clade (nodes 4–9)

This clade contains the last seven taxa. A detailed discussion is called for in the case of each node. Node 4 sep-

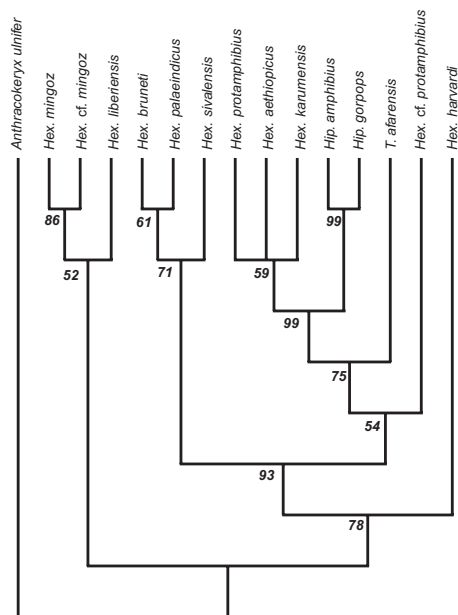

Figure 6. Strict consensus tree of the three most parsimonious trees obtained from the cladistic analysis (length = 81, CI = 0.6420, RI = 0.7752). In *italic-bold*, the bootstrap results are given as an indication of clade robustness.

arates *Hex. cf. protamphibius* from the six other taxa. Weston (1997, 2003) gave this name to the Kanapoi (West Turkana, Kenya) hippopotamid to emphasize its derived character, exhibiting some affinities with *Hex. protamphibius*. Initially, Coryndon (1976, 1977) associated this material with the older and more primitive *Hex. harvardi* from Lothagam (West Turkana, Kenya). Moreover, Weston (1997, 2003) included in *Hex. cf. protamphibius* the Allia Bay (East Turkana, Kenya) fossils and some specimens from the Apak member at Lothagam. Finally, she linked these specimens with the hexaprotodont material from the base of the Shungura Formation, lower Omo valley, Ethiopia (named *Hex. protamphibius turkanensis* in Gèze, 1985). As the Allia Bay material is still under study, I based my observations only on the Kanapoi specimens. My observations of the Omo fossils tend to support Weston's opinion about them. However, a complete revision of the Omo species is needed before reaching a definite conclusion. In these circumstances, it is not surprising that node 4 appears to be weakly supported.

The following node (5) is better supported. It associates the species *Trilobophorus afarensis* (Hadar, Afar region, Ethiopia) with the genus *Hippopotamus* and the *aethiopicus*–*karumensis*–*protamphibius* clade. This conflicts with the initial phylogenetic interpretation of the Hadar material. Indeed, following Gèze (1980, 1985), it would belong to a lineage originating in a species older than *Hex. harvardi*. As a consequence, Gèze attributed it to a new genus and

species, *Trilobophorus afarensis*. In fact, this view rested essentially on the bony contacts in the lachrymal area, claimed to be unique; the lachrymal being separated from the nasal by a frontal process of the maxillary bone, instead of a maxillary process of the frontal as in *Hexaprotodon* (*sensu* Coryndon, 1977). In a general examination of the Hadar fossils, I could not confirm this feature. Some pen marks on the material, probably from Gèze, indicate a misinterpretation of the anatomy of these specimens. These remains show a rather long contact between the nasal and the lachrymal (character 5, state 2). The derived character states of this material, interpreted by Gèze (1980) as convergences with *Hip. amphibioides*, naturally place the species *afarensis* within this clade.

The genus *Hippopotamus*, on the one hand, and the *aethiopicus*–*karumensis*–*protamphibius* group, on the other, are sister groups as indicated by a short and globular braincase (character 14, state 2), less than three lower incisors (character 31, states 1–2), anterior projection of developed canine processes (character 21, states 1–2; character 22, state 1). However, two incongruities need to be pointed out, based on the most parsimonious trees. (i) The long lachrymal–nasal contact observed in *Hippopotamus* and *afarensis* (character 5, state 2) is at odds with the inferred transition to minimal or variably developed lachrymal–nasal contact in the *aethiopicus*–*karumensis*–*protamphibius* group. (ii) Another apparently unparsimonious change is the disappearance of the orbital anterior border notch (reversion of the character 10) at node 5 and its reappearance, deep and wide, as an apomorphy of the genus *Hippopotamus* (node 9). However, this change is better resolved with a DELTRAN option. The reversion then occurs then at node 7 and implicates, at node 9, the acquisition of a deep notch from a weak notch (state 1).

The relationships between the three Pliocene Turkana species, at nodes 7 and 8, are not resolved in this analysis. The differences between the three cladograms concern three characters: 19, 35 and 36. For these three characters, each of these cladograms requires a reversion for two taxa while the third one shows a character state in common with the two *Hippopotamus* species.

Finally, the well supported monophyly of the genus *Hippopotamus* (node 9) is noted.

DISCUSSION: TOWARDS A REVISED PHYLOGENY FOR THE HIPPOS

THE NECESSARY SPLITTING OF THE GENUS *HEXAPROTODON*

Currently, a consensus dominates the discussion on hippo phylogeny: the genus *Hexaprotodon* depicted in

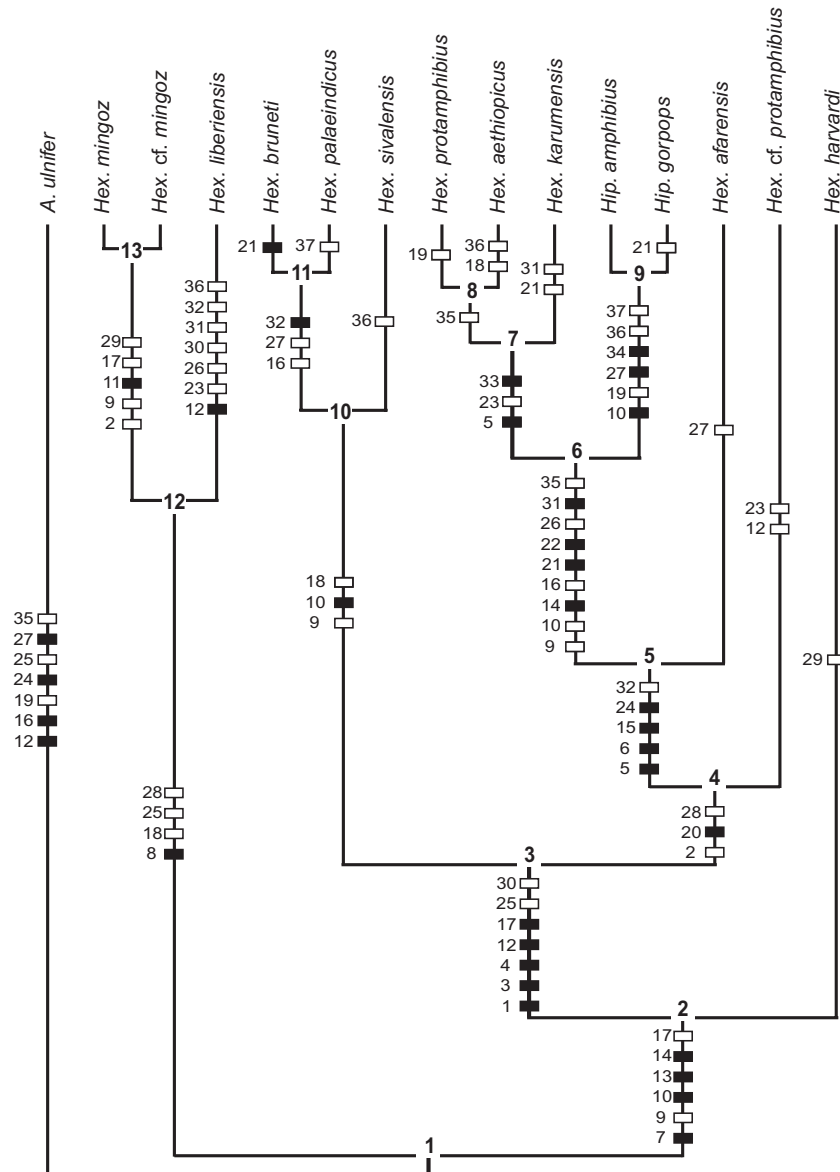

Figure 7. Second of the three most parsimonious tree obtained from the cladistic analysis. The bold numbers indicate the nodes. The numbered boxes indicate the ACCTRAN character state changes (white boxes indicate reversions and convergences).

Coryndon (1977) is paraphyletic. Therefore, the taxonomy used for the Hippopotamidae does not reflect the agreed upon phylogeny. Until now, only two questionable solutions have been put forth to resolve this dilemma.

One solution was briefly mentioned previously. Based upon Stuenes's (1989) discussion of generic characters, Harris (1991) evoked a hippo 'phenotypic plasticity' that could alternatively be responsible for a terrestrial morphology (corresponding to *Hexaprotodon*) and for an aquatic morphology (corresponding to *Hippopotamus*). If this assertion is correct, the current

taxonomy could be validated, and thus the two genera employed together, not as evolutionary stages, but as 'ecological grades': one terrestrial and one aquatic, respectively. This solution invokes an important ecophenotypism within only one lineage, and which is admittedly somewhat unusual for a large mammal family, and moreover no serious palaeoecological evidence is currently available to support it. In fact, several species of the genus *Hexaprotodon* cannot really be regarded as more terrestrial and/or more primitive than those of the genus *Hippopotamus*. For example, the orbit elevation in *Hex. karumensis* and *Hex.*

palaeindicus compares closely to elevated orbits seen in the most derived specimens of *Hippopotamus* for this character (Fig. 8). The orbit elevation is recognized as an obvious adaptation to a life near the water surface. *Hex. protamphibius* is a very close relative of *Hex. karumensis*, and the same relationship is recognized between *Hex. sivalensis* and *Hex. palaeindicus* (see the above parsimony analysis; Hooijer, 1950; Harris, 1991). *Hexaprotodon protamphibius* and *Hex. sivalensis* have much lower orbits that would indicate more terrestrial habits. Therefore, a supporter of 'ecological grades' should include *Hex. karumensis* and *Hex. palaeindicus* in the 'aquatic grade' *Hippopotamus*, while some of their closest relatives would be placed in the 'terrestrial grade' *Hexaprotodon*. This highly confusing situation contradicts Harris's (1991) remark (p. 57): 'Whether or not *Hippopotamus* and *Hexaprotodon* are merely form genera, there are consistent differences between terrestrially adapted and aquatically adapted hippos that makes it convenient to retain these generic names for purposes of communication'. Such obvious aquatic adaptations are better interpreted as convergences within several distinct lineages.

The other solution is an easy way out: it would consist in merging all such species within one genus, *Hippopotamus* (following the priority rule). This solution has been proposed on several occasions, but apparently with different motives. Pickford (1983) did not give evidence to justify his use of the name *Hippopotamus* for the *Hexaprotodon* species. More recently, Pickford (1993) has employed *Hexaprotodon* as a subgenus, in the way it was originally put forth, but without further explanation. Stuenes (1989) criticized the characters most frequently used to distinguish *Hexaprotodon* from *Hippopotamus* and suggested the irrelevance of the nomen *Hexaprotodon*. She mainly built her argument around the Madagascan Holocene hippos. One should be cautious to deny the validity of all the observations based on continental material, given the peculiar evolutionary of modes insular faunas (Sondaar, 1977). The position adopted in Hooijer (1950) has been cited already and is also the most defensible. If Asian hippopotamids constitute an isolated lineage, the attribution of a genus name to this lineage implicates the creation of new genera for the African and European species that show many differences with *Hippopotamus*. His reluctance to do so was a consequence of the lack of data on these species. Now many are much better known. Above all, a fundamental reason not to merge all hippos in a single genus is that this fusion would conceal taxonomically the important events of the family's history. It is difficult to approve of such an option, which would moreover contrast strongly with taxonomic recognition for other groups of equivalent diversity, the African Plio-Pleistocene Suidae being a



Figure 8. An example of convergence in the Hippopotamidae: orbit elevation. From bottom to top, right lateral views of the neurocrania: KNM-WT 19633, *Hippopotamus gorgops* from the Nachukui Formation, West Turkana, Kenya, housed at the NMK, Nairobi; 36824, *Hexaprotodon palaeindicus* from the Narbada beds, Central India, housed at the NHM, London; KNM-ER 798, holotype of *Hex. karumensis*, from the Koobi Fora Formation, East Turkana, Kenya, housed at the NMK, Nairobi. The elevated orbit is related to an aquatic way of life (Mazin & Buffrénil, 2001), indicating a preferential position at the air/water interface. These three species belong to three different lineages and evolved from forms with much lower orbits.

major example (see, among others, Harris & White, 1979; Cooke, 1985). Morphological disparity is strongly marked in the Hippopotamidae, and particularly within the genus *Hexaprotodon*, which regroups some species as dissimilar as *Hex. karumensis*,

Hex. iberiensis and *Hex. sivalensis*. Although the employment of several genera, rather than only one, is also subjective, it is more informative to use a taxonomy related to the available phylogenetic data.

The above analysis fully confirmed the paraphyly of the genus *Hexaprotodon*. The genus *Hippopotamus* seems to be based firmly on synapomorphies. Moreover, the analysis effectuated here shows that several clades can be recognized on morphological grounds within the family Hippopotamidae. The revision of hippo phylogeny is linked with the requisite adoption of phylogenetic systematics, that supports a splitting of the genus *Hexaprotodon* and names for these clades. This reformation can be carried out with the results of the parsimony analysis presented above. However, this approach is not wholly satisfying. Some remarks of Harris (1991) in regard to the importance of aquatic adaptations cannot be neglected. Thus, Weston (2000) concluded as follows: 'The parallelism that results from what appears to be successive invasion of aquatic and terrestrial niches needs to be taken into consideration when unravelling the history of this extraordinary group of mammals'. This parallelism frequently affects cranial structures (see Fig. 8), which of course play a major role in the definition of the basal nodes of the phylogenetic trees. Several strong intraspecific selective pressures may also induce the parallel modifications seen in the skull regions committed into fights, i.e. mainly the rostrum.

In order to circumvent this difficulty, at least partially, further attention must be given to the morphology of the mandibular symphysis. Indeed, the symphyseal area serves to effectively discriminate different Hippopotamidae species and, for some, indicates clear evolutionary trends during the Mio-Pliocene (Weston, 1997, 2000; Boissérie *et al.*, 2003; Boissérie & White, 2004). Hence, its phylogenetic significance is undoubtedly important. However, this structure can only be described accurately through a set of continuous variables. Given the difficulties attendant on coding these conditions, only a few such symphysis characters have been included in the present data matrix (see above, the character list). Other mandibular data were, however, examined and compared. Principally, they are: relative proportions of the cross section of the symphysis (height/length); relative robustness of this cross section (thick or thin); length of the symphysis relative to the width. A different feature, also examined, was the length of the premolar row relative to the length of the molar row. Those parameters were compared between taxa included in the cladistic analysis. Morphologies, especially those of the sagittal cross-section of the symphysis, appear to be similar between taxa within the following groups: (1) *Hex. mingozi* and *Hex. cf. mingozi* (Boissérie *et al.*, 2003); (2) *Hex. sivalensis*,

Hex. palaeindicus and *Hex. bruneti* (Boissérie & White, 2004); (3) *Hex. karumensis*, *Hex. protamphibius*, *Hex. aethiopicus*; (4) *Hip. amphibius*, *Hip. gorgops*. The other species showed mandibular proportions and shape that distinguished them from all the other taxa. These data are summarized graphically in Figure 9. In fact, the comparison of mandibular morphologies lead to visually discriminate groups similar to the clades of smallest rank obtained in the parsimony analysis. On this basis, it was more difficult to conclude on relationships between those different clades. Nevertheless, this confirms that mandibular shape and proportions allow us to recognize when species are closely linked. Therefore, when it was possible, these mandibular features were used to define the relationships of species that were not included in the cladistic analysis.

As a consequence, the new classification proposed below for the Hippopotamidae is based on the foregoing parsimony analysis, but also on those complementary observations (which are further discussed in the following section). Here two new genera are proposed, the genus *Choeropsis* is validated and the genus *Hexaprotodon* is redefined and reconstituted.

SYSTEMATIC PALAEOLOGY

This new proposed phylogeny, and its taxonomic consequences (discussed below, see Figs 9 and 10), may be compared to the phylogeny (Fig. 1) combined from Harrison (1997) and Weston (2000). For the shared taxa, they mainly differ in the following aspects:

1. the position of the Liberian hippo, which belongs to a clade including the two Chadian forms, and being perhaps the sister group of all the other hippos (excluding *Kenyapotamus* Pickford, 1983);
2. the grouping of the Lothagam, Abu Dhabi and Rawi hippos;
3. the grouping of the three Plio-Pleistocene species from the Turkana basin (*aethiopicus*-*karumensis*-*protamphibius*).

The monophyly of the genus *Hippopotamus* and its close relation with *Hex. protamphibius* are preserved, as is also the case for the position of the two Afar species described in Gèze (1985).

CLASS MAMMALIA LINNAEUS, 1758
ORDER ARTIODACTYLA OWEN, 1848
FAMILY HIPPOPOTAMIDAE GRAY, 1821
GENUS *SAOTHERIUM* GEN. NOV.

Description

Diagnosis: Hexaprotodont, with the following apomorphies: cranial roof showing an antorbital angle

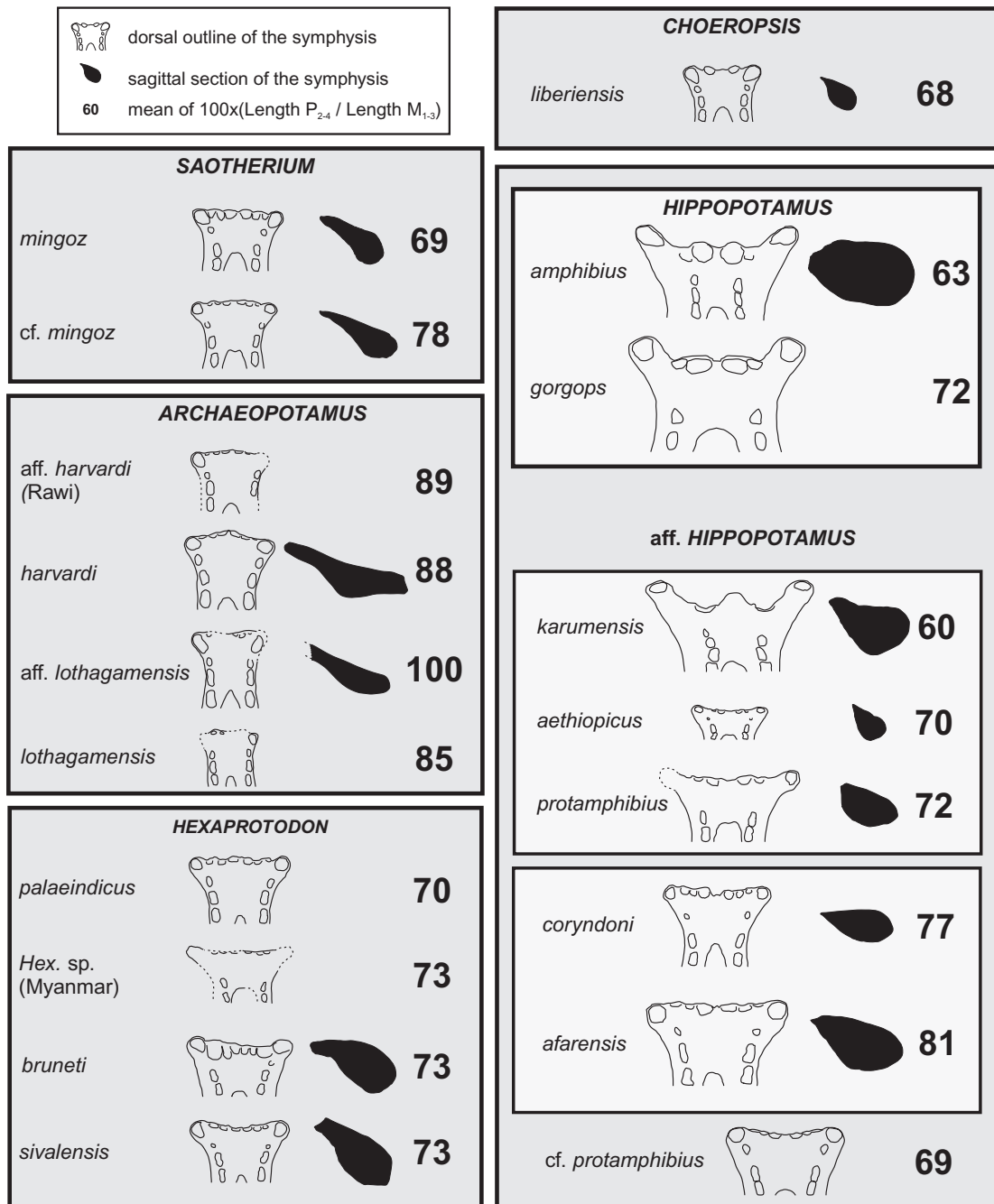

Figure 9. Mandibular anatomy within the Hippopotamidae. This figure shows the new taxonomic divisions of the family Hippopotamidae and, for each discussed taxon, some of the mandibular characters that provided additional support to the clades identified in the parsimony analysis (boxes in this figure). These features include: the general shape of the mandible, with expansion of the canine processes and relative length of the symphysis (seen in the dorsal outlines); the shape of the symphysis sagittal cross section; the length of the premolar row relative to the length of the molar row. The figure shows the following features for the taxa listed under each genus name: *Saotherium*, very inclined symphysis with thin cross-section and poorly developed canine processes; *Archaeopotamus*, relatively long and shallow symphysis with poorly developed canine processes and longer premolar rows than in any other clade; *Hexaprotodon*, wide symphysis but with poorly differentiated canine processes, very robust symphysis in cross section; *Choeropsis*, very short symphysis globular in cross section and poorly developed canine processes; *Hippopotamus* and aff. *Hippopotamus*, short symphysis globular in cross-section (lacking a projected incisor alveolar process) and strong extension of the canine processes – the latter feature being not salient in the Afar species (aff. *Hip. corydoni*, aff. *Hip. afarensis*) and aff. *Hip. cf. protamphibius* from Kanapoi.

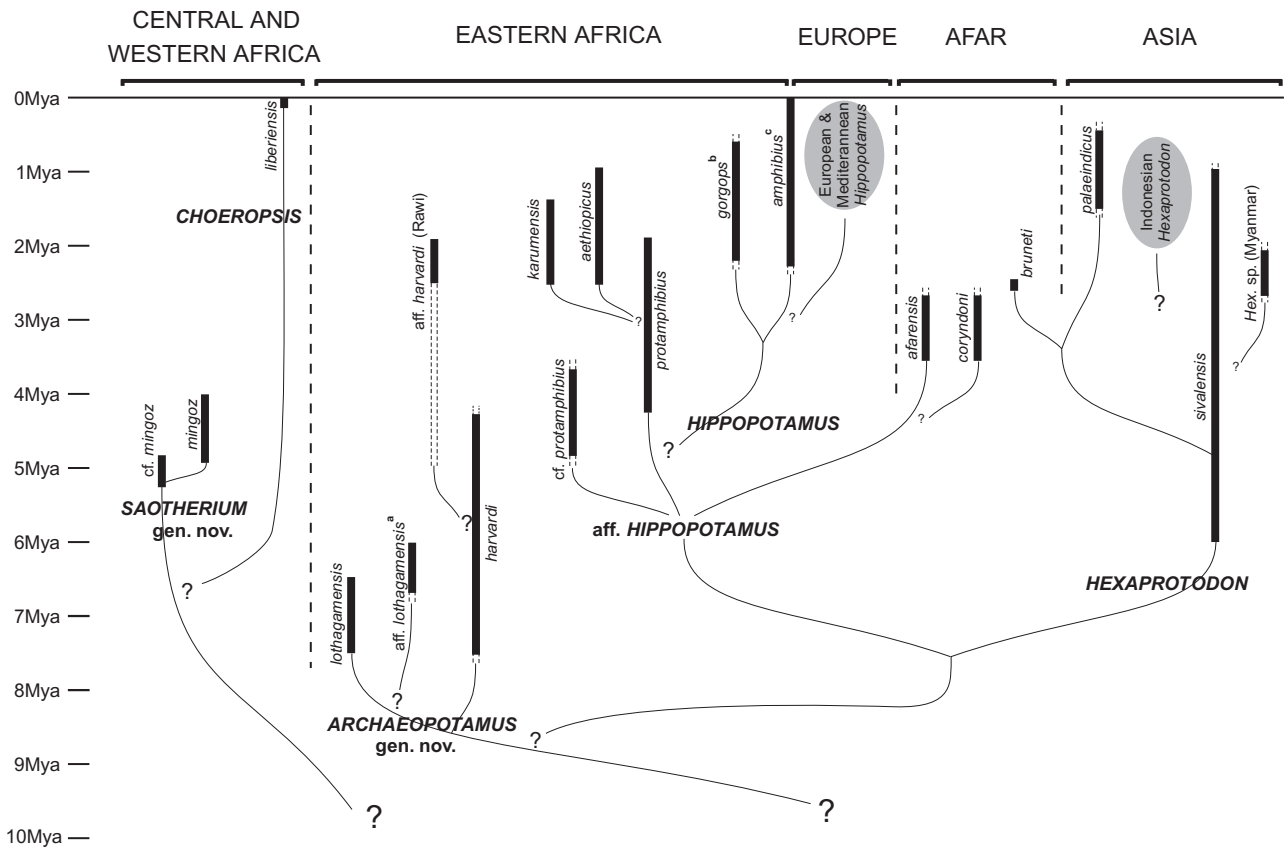

Figure 10. A new phylogeny for the Hippopotamidae. Geographical distribution: ^anot Eastern African, but from Abu Dhabi, the Arab United Emirates, the Arabic Peninsula (see Gentry, 1999); ^bknown in Eastern Africa but also in Oubeidiyeh, Israel (see Faure, 1986) and maybe in Algeria (Geraads, 1980); ^cknown in Africa but also in continental Europe (see Mazza, 1995).

in lateral view; skull very high above the molars; slender mandibular symphysis in the sagittal plane. Also exhibiting these plesiomorphic or convergent features: orbits below the cranial roof; slender zygomatic arches; cylindrical braincase; slender and low sagittal crest; laterally developed occipital plate; maxillary process of the frontal separating the nasal and the lachrymal bones; short extension of the canine processes; lingual border of the lower cheek tooth alveolar process lower than the labial border.

Type species: *Saotherium mingoz*, from Kollé (Chad), Lower Pliocene (Boisserie *et al.*, 2003).

Other material: *Saotherium cf. mingoz*, from Kossoum Bougoudi (Chad), Lower Pliocene (Boisserie *et al.*, 2003).

Remarks: The diagnosis is the same as for the type species, excluding those characters that differentiate the two known taxa, or that have not been seen in both forms.

Etymology: From the 'Sao', an enigmatic medieval civilization known in the Chad basin (Lange, 1989).

Geographical distribution: Djurab desert, Lake Chad basin (Chad, Central Africa).

Temporal distribution: early Pliocene, between the Mio-Pliocene boundary and 4.0 Mya (see Brunet *et al.*, 1998; Brunet & MPFT, 2000).

Discussion

In their description (Boisserie *et al.*, 2003), the two Djurab Pliocene hippos are shown to possess an association of original cranial features: the antorbital angle of the cranial roof and the correlated anterior convergence of the nasal toward the palate; the important relative height of the skull above the molars; the elongated braincase with a rounded transversal section and a weak postorbital constriction ('cylindrical' aspect). In this respect, these hippopotamids differ considerably from the other known hippos. For this reason, Boisserie *et al.* (2003) evoked

an independent hippo lineage in central Africa originating at the Mio-Pliocene boundary if not before. This opinion is confirmed by the position of these forms in the parsimony analysis (Figs 6, 7), showing also many primitive traits in this morphology. The mandibular morphology, especially the symphyseal sagittal section between the central incisors (see Fig. 9), reinforces this position; the association of a general thinness and of a very inclined main axis differs from the conditions seen in the other Hippopotamidae. Finally, it appears that the two Djurab Pliocene hippopotamids constitute a peculiar lineage. Following the above discussion, this lineage is separated here from all other Hippopotamidae at the generic level.

On the other hand, the parsimony analysis relates these Pliocene hippopotamids to the extant Liberian hippo. However, the long list of convergences accumulated by the latter taxon, its apomorphies and autapomorphies (see below) and the absence of the peculiar cranial structure of *Saotherium* obviously differentiate these animals. In fact, these taxa mainly share character states that are plesiomorphic or convergent with other taxa in the analysis, with the exception of the enlarged orbit size (character 8, state 1, see Fig. 3 and the above results). However, given the available data, it is difficult to define the most probable primitive state of this feature and hence its probable evolutionary trend. Therefore, this relationship must be carefully envisaged, but not completely ignored.

Evolutionary trends: The comparison of the Kossom Bougoudi material and the younger Kollé material led Boissérie *et al.* (2003) to propose some possible evolutionary trends: a relative shortening of the premolar row and a global size decrease.

GENUS *CHOEROPSIS* LEIDY, 1853

Description

Emended diagnosis: Small-sized genus, distinct from all the other known Hippopotamidae by its downwardly bent nasal anterior apex, which clearly passes the premaxillae-nasal contact anteriorly; orbits clearly below the cranial roof; strong posterior nasal spine of the palatine; large and elongated tympanic bulla, which is apically rounded and without marked muscular process; presence of a lateral notch on the basilar part of the basi-occipital, immediately posterior to the muscular tubercles; down-turned sagittal crest. *Choeropsis* shares many characters with the most primitive Hippopotamidae: weak extension of the canine processes (both lower and upper); facial crest regularly convex in ventral view, gradually sloping from the zygomatic arch toward the maxilla; slen-

der zygomatic arch in ventral view; lachrymal separated from the nasal by a long maxillary process of the frontal; orbit anterior to the level of contact between M/2-M/3 seen in lateral view; weak supra-orbital apophyses; braincase elongated and transversally rounded. *Choeropsis* also presents some derived features convergent on several other Hippopotamidae: diprotodont mandibular symphysis, short and upright; gonial angle laterally everted; P4s generally without accessory cusps.

Type species: *Choeropsis liberiensis* (Morton, 1844), extant, same diagnosis as for the genus.

Geographical distribution: Coastal valleys and plains of the Guinean gulf (Sierra Leone, Liberia, Ivory Coast, Nigeria, Guinea-Bissau?), Western Africa (from Eltringham, 1993, 1999). Corbet (1969) created a subspecies, *C. liberiensis heslopi*, for the delta of Niger populations.

Temporal distribution: Genus exclusively known in the present, with only one species classified vulnerable by the IUCN (Eltringham, 1993, 1999); the oriental subspecies may be already extinct.

Discussion

The extant Liberian hippo shows a mosaic of characters. First, almost all of its cranial character states appear plesiomorphic in the parsimony analysis, except for characters 8 and 12 (large orbit size, state 1; sagittal crest slope, state 3). Second, the mandible and the dentition display some very derived features, also found in some other hippopotamids (convergences). The symphysis is very inclined (character 18, state 1), the gonial angles are divergent (character 25, state 1), the reduced number of incisors (characters 26 and 31, respectively, states 1 and 2), the P4s are simple (characters 30 and 36, states 1). The overall morphology of the mandible is, similarly, both derived and primitive, the symphysis being short but without strong canine processes. Finally, this species has some autapomorphies (noted 'A' on Figs 2 and 3): the anterior morphology of the nasal (A3), the presence of a notch on the basilar part of the basi-occipital (A2), the developed posterior nasal spine of the palatine (A1). These non-informative characters have not been included in the cladistic analysis. A fourth autapomorphy, the down-turned sagittal crest (character 12, state 3) is relatively frequent in the Anthracotheriidae and is generally regarded as a plesiomorphy, reinforcing the 'primitive aspect' of this species.

All these plesiomorphies, autapomorphies and convergences show that this species probably issued from a lineage distinct from all the other hippopotamids a considerably long time ago. If the Pliocene Chadian hippos are the closest relatives, their respective histo-

ries diverged for more than 5.0 Myr. The evolution of this species, having resulted in an overall unique morphology within this family, justifies its distinctness at the generic level, as recommended in Harrison (1997). Hence, I propose to maintain this species within the genus initially created for it: *Choeropsis*.

Remarks: The position of the Liberian hippo with *Saotherium* within the sister group of all other hippopotamids, except *Kenyapotamus*, calls for some comments on ecology. This hippo is frequently mentioned as more terrestrial than the other modern species, *Hip. amphibius*. However, it presents several physiological characters that are related to a semiaquatic way of life: peculiar skin without sweat glands and retaining few hairs, strong muscular valves to obstruct the ears and nostrils underwater. These characters are shared with the common hippo. Hence, they could have been present in the common ancestor of those animals, which, according to the phylogenetic hypothesis proposed here, is the ancestor of all hippos except *Kenyapotamus*. This would slightly reinforce the idea that aquatic behaviour in whales and hippos could be inherited from a common ancestor. This would also preclude characterizing the semiaquatic habits of fossil species only on the basis of elevated orbits.

GENUS *ARCHAEPOTAMUS* GEN. NOV.

Description

Diagnosis: Hexaprotodont, characterized by having a very elongate mandibular symphysis relative to its width. This symphysis bears also an incisor alveolar process strongly projected frontally, very procumbent incisors, and canine processes poorly extended laterally and not extended anteriorly. The length of the lower premolar row approaches the length of the molar row. The horizontal ramus height is low compared to its length but tends to increase posteriorly. The gonial angle of the ascending ramus is not laterally everted.

Type species: *Archaeopotamus lothagamensis* (Weston, 2000), from Lothagam, Kenya, Upper Miocene.

Other material: *Archaeopotamus harvardi* (Coryndon, 1977); *Archaeopotamus* aff. *lothagamensis* (*Hex. aff. sahabiensis* in Gentry, 1999); *Archaeopotamus* aff. *harvardi* (see below).

Etymology: 'The ancient of the river', to denote that this genus is for now the oldest recorded among well-identified hippos, in a family closely linked to freshwater.

Geographical distribution: Lake Turkana basin (Kenya); Baynunah Formation, Abu Dhabi (the United Arab Emirates); Rawi, Lake Victoria (Kenya).

Temporal distribution: Mio-Pliocene, between 7.5 and 1.8 Mya.

Discussion

Two Miocene hippopotamids have been recently described from mandible elements: *Hex. aff. sahabiensis* (Gentry, 1999) and *Hex. lothagamensis* Weston (2000). These mandibles are characterized by their marked lengthening in the sagittal plane together with an almost negligible development of the canine processes, thus accentuating the generally narrow aspect of the symphysis. Weston (2000) indicated also that the small species *lothagamensis* could be an 'ontogenetically scaled-down version' of *Hex. harvardi*: it compares closely with the juvenile specimens of this larger species (see Fig. 9). The biometrical study of the mandibular symphysis proportions confirmed the close relationship between *Hex. harvardi*, *Hex. lothagamensis* and *Hex. aff. sahabiensis*. As demonstrated in Weston (2000), they show a ratio of symphysis length vs. symphysis width that is strikingly different from the ratio seen in other hippopotamids (Fig. 11). There is one exception, this unusual ratio being also known for a mandible recovered at Rawi (Upper Pliocene strata of Kenya), purportedly related to *Hex. imagunculus* by Kent (1942). This mandible principally shows some anatomical affinities with those of the species *harvardi* (see remarks below). These hippopotamids are singular in that the gonial angles are not shifted laterally from the axes of the horizontal rami. Finally, the specimens present a relatively long premolar row P/1–P/4 as compared to the molar row M/1–M/3. The mean values of this ratio are lower in other species (Fig. 9).

Weston (2000) argued that elongate mandibular symphysis (Fig. 11) should be primitive within the family, the hippopotamids showing, in some cases, a trend toward shortening of the symphysis. It seems, however, that this opinion is based on the incidental fact that at the time the Lothagam hippos were the only well-known Miocene hippos and on the presumption that the Hippopotamidae derived probably from an animal having a narrow mandibular symphysis. Several comments are in order:

1. the immediate forerunner of the Hippopotamidae remains unknown, and hence the ancestral morphology is likewise unknown (the symphysis of *Kenyapotamus* is not sufficiently preserved to further elucidate this issue);
2. *Choeropsis liberiensis* and *Saotherium*, as described above, exhibit in many characters a cranial morphology still more primitive than that of *Hex. harvardi* (notably characters 7, 10,

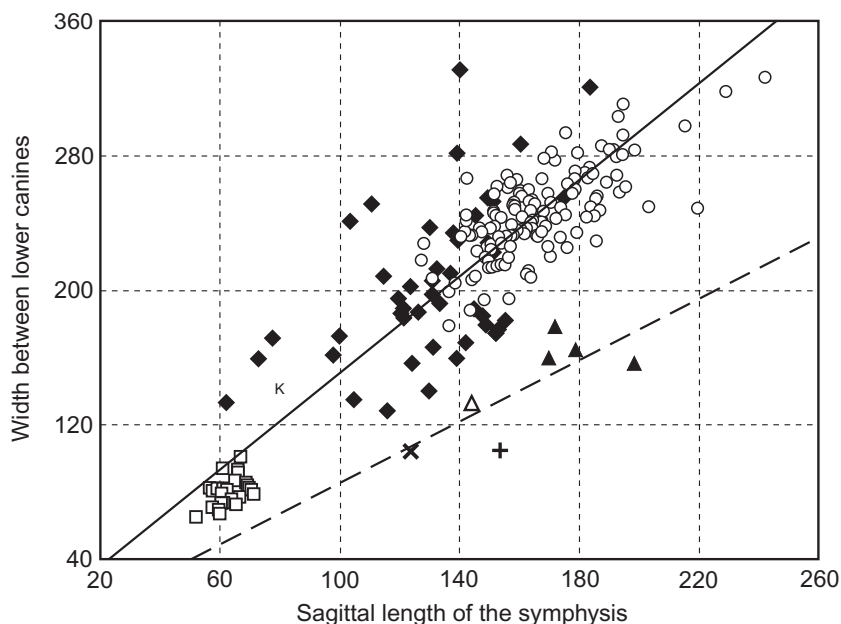

Figure 11. Comparison of mandibular symphysis measurements between the ‘narrow muzzled’ hippos and other hippopotamids (only adult specimens were included): bivariate plot of sagittal length of symphysis vs. width between lower canines (all adult specimens). Legend: \times , *Archaeopotamus lothagamensis* from Lothagam, Kenya; +, *A. aff. lothagamensis* from Abu Dhabi, United Arab Emirates; \blacktriangle , *A. harvardi* from Lothagam, Kenya; \triangle , *A. aff. harvardi* from Rawi, Kenya; K, UMP 6202, *Hexaprotodon* ? cf. *imagunculus* from Kazinga Channel, Uganda; \blacklozenge , other fossil hippopotamids; \square *Choeropsis liberiensis*, extant; \circ , *Hippopotamus amphibius*, extant. Broken line: regression line for the genus *Archaeopotamus*; unbroken line: regression line for all the other individuals.

13, 14), as well as having a shorter mandibular symphysis;

3. a newly recovered, well-documented hippopotamid (still under study) has recently been unearthed in Chad from a level probably contemporary with the lower Nawata Formation of Lothagam (Vignaud *et al.*, 2002), which also exhibits a symphysis shorter than in the hippos of Lothagam.

Hence, the adjective ‘primitive’ should be applied only with caution to the narrow mandibular symphysis of the Lothagam, Abu Dhabi and Rawi hippopotamids, even if this option cannot be discarded for now.

The fact remains that Weston’s (2000) phylogeny placed *Hex. lothagamensis* and the Abu Dhabi hippo into the sister group of all other hippos (Fig. 1), on shared mandibular morphology. Similarly, I propose here to include *Hex. harvardi* and the Rawi specimen in this same clade. This interpretation is also supported in a recent work (Boisserie & White, 2004). Owing to the position of *Hex. harvardi* in the cladistic analysis (Figs 6, 7), this clade, which might informally be called the ‘narrow muzzled hippos’ (after Gentry, 1999), might be the sister group of all other hippos, except of course *Choeropsis* and

Saotherium (Fig. 10). The great temporal range of *harvardi* and the late presence (at the end of the Pliocene epoch) of a related form in Rawi appears to indicate that the history of these narrow muzzled hippos constituted an important and distinctive, albeit peculiar, part of the family Hippopotamidae, in terms of its protracted duration and diversity. In order to acknowledge its importance, this clade is elevated here to the genus rank with the name *Archaeopotamus*.

Weston (2000) suggested that the Abu Dhabi form is more closely related to *A. lothagamensis* than to *A. harvardi*: the former two hippos share a canine cross section compressed from side to side and a P/4 with two main cuspids (lingual and buccal) of the same height. On the other hand, the canines of *A. harvardi* and the Rawi mandible show a less compressed section and their P/4s bear a more reduced and distal lingual cuspid. They differ also from *A. lothagamensis* and, particularly, from the Abu Dhabi hippo, in having a lower symphysis and the canine processes slightly more developed. However, *A. lothagamensis* differs from the Abu Dhabi material by its smaller size and some other features (Weston, 2000). In the latter, the symphysis height and the oblique orientation of the incisors show some similar-

ities to those of *S. mingoz*. Despite its similarities with *A. harvardi*, the Rawi mandible is too small and its I/2 too reduced in comparison to the I/1 to be included in this species. For these reasons, the Abu Dhabi material is denoted here as *A. aff. lothagamensis*, while the Rawi mandible is denoted *A. aff. harvardi* (see Figs 9, 10).

Remarks: (1) When Gentry (1999) first described *A. aff. lothagamensis*, he called attention to certain resemblances to *Hex. sahabiensis* from Sahabi (Libya), and thereupon proposed the designation *Hex. aff. sahabiensis*. However, the Libyan species is based on such fragmentary material that it appears difficult to ascertain on its position in the phylogeny (see below). Therefore, for the attribution of the Abu Dhabi hippo, it is more realistic to underline its resemblance to the small form of Lothagam. (2) In Weston (2000), *Hex. crusafonti* from localities of the Miocene (MN-13) of Spain was also considered related to *A. lothagamensis* and to *A. aff. lothagamensis*. However, as I have not yet seen these remains, I prefer to exclude them from consideration here.

GENUS *HEXAPROTODON* FALCONER & CAUTLEY,
1836

Description

Emended diagnosis: Hexaprotodont; characterized by a very high robust mandibular symphysis, relatively short in spite of its canine processes which are not particularly extended laterally; dorsal plane of symphysis very inclined; thick incisor alveolar process, frontally projected; some relatively small differences between the incisor diameters, the I/2 being usually the smallest; laterally everted but not hook-like gonial angle; orbit having a well developed supra-orbital process, and a deep but narrow notch at its anterior border; thick zygomatic arches; elevated sagittal crest on a transversally compressed braincase. Some constant features of this genus appear to be primitive: the strong double-rooted P1/ the quadrangular lachrymal, separated from the nasal bone by a long maxillary process of the frontal.

Type species: *Hexaprotodon sivalensis* Falconer & Cautley, 1836, from Mio-Pliocene strata of the Siwalik hills, India/Pakistan.

Other material: In Asia, *Hex. palaeindicus* (Falconer & Cautley, 1847) and the perhaps synonymous *Hex. namadicus* (Falconer & Cautley, 1847), *Hex. sp. indet.* from Myanmar and the Indonesian hippos of Pleistocene age (see Hooijer, 1950); and in Africa, *Hex. bruneti* from Bouri, Afar, Ethiopia (Boisserie & White, 2004).

Geographical distribution: Principal occurrences in the Indian subcontinent (see specially Lydekker, 1884; Colbert, 1935; Hooijer, 1950): Northern India and Pakistan, Central India, Nepal, Sri Lanka; in Myanmar (Colbert, 1938); in Indonesia (Hooijer, 1950); in Ethiopia, Afar depression (Boisserie & White, 2004).

Temporal distribution: In Asia: end of Miocene in the Siwaliks (5.9 Mya; see Barry *et al.*, 2002) to late Pleistocene in Central India and Indonesia; in Africa: only reported around 2.5 Mya.

Discussion

The central part of the consensus cladogram analysis (Fig. 6) comprises two clades: on the one hand, various East African hippopotamids and the genus *Hippopotamus*; on the other, the three species *sivalensis* and *palaeindicus* of Asia, and *bruneti* of Ethiopia. This confirms a general consensus, established in the literature since the 19th century and persisting until now (Falconer & Cautley, 1836; Lydekker, 1884; Colbert, 1935; Hooijer, 1950; Coryndon, 1978; Harrison, 1997; see also Fig. 1), which recognizes one peculiar lineage of hippopotamids within Asia. The singular *Hex. bruneti* constitutes a presumptive migrant of this lineage into Africa (Boisserie & White, 2004). This lineage evolved separately as early as the late Miocene, disappeared through extinction only quite recently, and exhibited noteworthy diversity (ten different forms having been recognized by Hooijer, 1950). Given the position adopted in this work with respect to Hippopotamidae systematics, this lineage must represent a genus. Its name must be that initially given to the species *sivalensis*: *Hexaprotodon*. Two comments are called for. First, the emended diagnosis of *Hexaprotodon* is for now based largely on a unique mandibular morphology, especially the high and robust symphysis relative to its other general dimensions (Fig. 9). Second, a feature commonly retained in the previous *Hexaprotodon* diagnoses, the deep posterior groove of the upper canine, has been superseded: in *Hex. bruneti*, the upper canine is antero-posteriorly compressed and the depth of this groove is attenuated, although it is still obvious and wide, and cannot be confused with the small groove seen in the genus *Hippopotamus*.

Evolutionary trends: Within this complex lineage, several evolutionary trends can be recognized, for example the increase of the I/3 diameter relative to that of the other incisors (culminating in *Hex. palaeindicus* and especially in *Hex. bruneti*), the increasing elevation of the orbits (*Hex. palaeindicus*); and the increasing height of the molar crowns (*Hex. palaeindicus* and *Hex. sp. indet.* from Myanmar).

GENUS *HIPPOTAMUS* LINNAEUS, 1753*Description*

Emended diagnosis: Tetraprotodont, and having the following apomorphies: skull with an elongated muzzle; upper canines with a longitudinal and shallow posterior groove, narrow and covered with enamel; lower canines with strong convergent enamel ridges; deep and widely open notch on the orbital anterior border; limbs short and robust with very large quadridigitigrade feet. This genus displays many other features that are derived within the family, but which may be seen in other hippos: antorbital process of the frontal short to absent and a long contact between the maxillary bone and the lachrymal bone; high orbits; short globular braincase, with strong postorbital constriction; mandibular symphysis globular in sagittal section, without incisor alveolar process overhanging frontally; canine processes well developed laterally and frontally; molars high-crowned, compact and relatively long mesiodistally (modified from Gèze, 1980 and Harris, 1991).

Type species: *Hippopotamus amphibius* Linnaeus, 1758, extant.

Other material: In Africa, *Hip. gorgops* Dietrich, 1928, and *Hip. kaisensis* Hopwood, 1926); several other species in Eurasia.

Geographical distribution: Africa, Madagascar (see Stuenes, 1989; Faure & Guérin, 1990), continental Europe (including the Caucasus) and the Mediterranean basin (see especially Faure, 1983, 1986; Vekua, 1986; Mazza, 1991); the genus name *Phanourios* proposed by Boekschoten & Sondaar, 1972) seems to be relevant for the small, peculiar *Hippopotamus* from Cyprus (see also Houtekamer & Sondaar, 1979).

Temporal distribution: The FAD of the genus *Hippopotamus* remains unclear, largely because it depends on the identity of some very fragmentary remains. Harris *et al.* (1988) reported some fossils from the Kataboi member of the Nachukui Formation (West Turkana, Kenya) denoted as *Hip. cf. kaisensis*. These are the oldest known evidence for this genus at least in the Turkana basin (this member is aged between 4.10 and 3.36 Myr, following Feibel, Brown & McDougall (1989). However, Faure (1994) attributed to *Hip. kaisensis* some dental and postcranial pieces from the lowest levels of the Nkondo Formation (Western Rift, Uganda), aged about 5.0 Myr.

Discussion

The species belonging to this genus are generally easy to recognize, particularly the morphology of anterior dentition. The monophyly of *Hippopotamus* has not been recently questioned, and the results of the par-

simony analysis confirm this view for the two principal African species (*amphibius* and *gorgops*). One should note that the number of species and their relationships within the genus are still a matter of debate. For example, all or part of the scarce material attributed to *Hip. kaisensis* Hopwood, 1926 could correspond to various other species (*Hex. protamphibius*, *Hex. karumensis* or *Hip. gorgops*, following Gentry, 1999) and/or be a synonym of *Hip. amphibius* (see Pavlakis, 1990). The discussion about the European forms in Mazza (1995), particularly on *Hip. incognitus* Faure, 1984, also illustrates the recent debates on *Hippopotamus* diversity.

GENUS AFF. *HIPPOTAMUS* LINNAEUS, 1853*Material*

The following taxa are noted aff. *Hippopotamus* (see discussion below): aff. *Hip. aethiopicus*, aff. *Hip. karumensis*, aff. *Hip. protamphibius* and aff. *Hip. cf. protamphibius* from the Plio-Pleistocene of the Turkana basin (Ethiopia and Kenya); aff. *Hip. afarensis* and aff. *Hip. coryndoni* from the Pliocene of the Afar depression (Ethiopia). The most complete appraisals of these hippos were given in Coryndon (1977), Gèze (1980), Harris (1991), and Weston (1997, 2003).

Discussion

It has already been said that the Plio-Pleistocene hippos from the Turkana basin require careful re-examination. This is also the case for those known from the Afar depression, essentially those from Hadar (Gèze, 1980, 1985). Preliminary observations on both Kenyan and Ethiopian collections have revealed to me that at least some of these East African species appear to have been defined inadequately. This may be responsible for some uncertainties and incongruities observed in the parsimony analysis (e.g. weakly supported position of aff. *Hip. cf. protamphibius*; partial reversion of the lachrymal area anatomy for the Turkana hippos; reversion of the anteorbital border notch presence; see also Fig. 7). A revision of these purported species could result in changes in their presumed relationships, and in the recognition of some distinct lineages. The existence of local lineages could possibly explain the difficulties recognized by Harris (1991: 57): 'As in the Turkana basin, it is possible to chart evolutionary change through time in one geographical entity but more difficult to fit the local story into a broader regional context'. This view may be supported by the clade *aethiopicus*-*karumensis*-*protamphibius*, obtained in the parsimony analysis (a close relationship between these three Turkana hippos was previously evoked in Harris, 1991). The similarities in the general morphology and propor-

tions of the mandible between the two Hadar species (see Fig. 9) could also lead to the recognition of a distinctive lineage in the Afar depression. Nevertheless, several problems must be considered, notably the position of aff. *Hip. cf. protamphibius*, which is still to be clarified (Weston, 2003), and the lack of consistent cranial data for aff. *Hip. coryndoni*. Consequently, it is premature to be more conclusive. Regardless, if the name *Hexaprotodon* is restricted to a distant lineage, another name must be employed to refer to these East African hippos. As a part of the same clade, the genus *Hippopotamus* is more closely related to them, but this genus has already been defined here in a precise fashion. For these reasons, I propose here to refer to these Lake Turkana and Afar hippos by a provisional term: aff. *Hippopotamus*. For the future revision of this group, the study of the new, often abundant material collected in the Middle Awash (Afar depression, Ethiopia) would most probably prove decisive.

INCERTAE SEDIS

North African and European taxa

Material: *Hexaprotodon ? crusafonti* (Aguirre, 1963); *Hexaprotodon ? hipponensis* (Gaudry, 1876); *Hexaprotodon ? pantanellii* (Joleaud, 1920); *Hexaprotodon ? sahabiensis* Gaziry, 1987; *Hexaprotodon ? siculus* (Hooijer, 1946).

Spatio-temporal distribution: The species *Hex. ? crusafonti*, *Hex. ? pantanellii* and *Hex. ? siculus* occurred during the end of the Miocene in Southern Europe, respectively, in Spain, continental Italy and Sicily. The two other species are African: *Hex. ? hipponensis* is only known from the early Pliocene (?) from Pont du Vivier (Algeria); *Hex. ? sahabiensis* was found at Sahabi, Libya (late Miocene, following Geraads, 1989).

Discussion: *Hex. ? crusafonti* (Aguirre, 1963) (from which *Hex. primaevus* Crusafont, Adrover & Golpe, 1964, is most likely synonymous) is mainly known from a partial, damaged, mandibular symphysis (see Lacombe *et al.*, 1986). Weston (2000) suggested a relation to *A. lothagamensis* for this early tetraprotodont, but I prefer to not speculate further without a close examination of this material. Harrison (1997) argued for the synonymy of the Sicilian and the Spanish species. He related it to the North African hippos (*hipponensis* and *sahabiensis*). The same author included *Hex. ? pantanellii* in the Asian hippo lineage. On the other hand, van der Made (1999) recommends the use of the name *pantanelli* for all the European late Miocene forms (including *siculus*, *crusafonti* and *primaevus*), and denied a close relationship between them and the Asian lineage. In fact, all these hippos have been described on the basis of scant dental

remains. Their affinities cannot be discussed because their fossils are too incomplete. Therefore, the generic attributions of these species are put aside *sine die*; their previous genus name must be accompanied by an uncertainty sign: *Hexaprotodon ?*.

THE WESTERN RIFT SMALL HIPPO CASE

Material: In the literature, the name *Hex. imagunculus* (Hopwood, 1926) was given to various small hippo material from the Western Rift area (Kaiso, Kazinga Channel, Semliki Valley, ...). The limits and validity of this taxon have been evaluated in various ways (see for example Misonne, 1952; Cooke & Coryndon, 1970; Erdbrink & Krommenhoek, 1975; Pavlakis, 1990; Faure, 1994). Following these authors, this material is considered here to belong to one or more, and probably several, small-sized species which lived in the Western rift basins and surroundings during the Pliocene.

Spatio-temporal distribution: The age of these different specimens ranges between 5.0 and 1.8 Myr (ages after Boaz, 1990, 1994; Faure, 1994; Ditchfield *et al.*, 1999).

Discussion: Following Pavlakis (1990), the name *Hex. imagunculus* should not be employed for anything other than the material from the type locality (Kaiso, Uganda). As it consists mainly of isolated teeth, the generic attribution of the Kaiso material cannot be ascertained on such limited evidence. I propose to denote this material: *Hex. ? imagunculus*. The Upper Semliki material should then be denoted: *Hex. ? cf. imagunculus* after Pavlakis (1990). The same term could be used also for the Ugandan material described in Faure (1994), also exclusively comprising isolated teeth and some postcranial material.

At first sight, one might be tempted to link the Rawi symphysis and the fragmentary skull M14801 from Kazinga Channel (Uganda) described in Cooke & Coryndon (1970). Indeed, the morphology of this skull seems primitive, in retention of an orbit positioned just below the cranial roof, but derived in having expanded supra-orbital processes, as in *A. harvardi*. However, a mandibular symphysis, also from Kazinga (UMP 6202; see Cooke & Coryndon, 1970: table 29, pl. 14A), is morphologically very different from that of *A. aff. harvardi*. It is also hexaprotodont, but presents some clearly distinct proportions (cf. Fig. 11) and a wide diastema I/1-I/1 which would rather recall the Pliocene hippos, especially *protamphibius* from the Turkana basin. Awaiting detailed review of the whole Kazinga sample, it is preferable to preserve the uncertainty, already favoured in Cooke & Coryndon (1970), for this possibly heterogeneous assemblage. Here also, I recommend at most the term *Hex. ? cf. imagunculus*.

CONCLUSION

The phylogeny of the family Hippopotamidae and its taxonomic resolution has remained problematic for too long. In this paper, focusing mainly on continental Africa and Asian Mio-Pliocene Hippopotamidae, some improvements are proposed in order to clarify the situation. For the first time, a thorough cladistic analysis has been conducted on the Hippopotamidae. This analysis notably confirms that: (i) the extant Liberian hippo belongs to a primitive and ancient lineage; (ii) the genus *Hexaprotodon sensu* Coryndon (1977) is paraphyletic; and (iii) the Asian hippopotamids belong to a separate lineage. It also suggests some affinities for the Pliocene Chadian hippo with the extant Liberian species, the sister group of all other hippos.

The genus *Choeropsis* has been validated and two new genera have been created: *Saotherium* for the Pliocene Chadian hippos and *Archaeopotamus* for the mostly Miocene 'narrow muzzled' hippos. The genus *Hexaprotodon* has been restricted to the Asian lineage and the genus *Hippopotamus* has been confirmed; the remaining uncertainties have been identified and discussed. One can note some harmony between this phylogeny and the geographical distribution of the family (Fig. 10).

Of course, several problems remain, and extended work is called for in order to obtain a global picture of Hippopotamidae phylogeny, especially the elucidation of both Turkana and Afar basin taxa. A comprehensive revision should also include the Pleistocene radiation of *Hippopotamus* in Europe and those of the various insular hippos (within the Mediterranean Sea, Madagascar, Indonesia). The discussion of the family origin should be pursued, including evaluation of the *Kenyapotamus* evidence. However, the present study has already made some progress toward the recognition and resolution of significant phylogenetic and biogeographical problems. Whereas a 'wastebasket genus' like *Hexaprotodon sensu* Harris (1991), or the grouping of the whole family into a single genus, can readily lead to some poorly justified taxonomic attributions, the definition of more restricted genera, largely based on cranial and mandibular features, should encourage us to be more cautious in attributing isolated dental and postcranial remains. Above all, these steps toward phylogenetic and taxonomic resolutions should provide a framework for future studies on the palaeoecology and palaeobiogeography of the Hippopotamidae.

ACKNOWLEDGEMENTS

This study was conducted with the support of the Mission Paléanthropologique Franco-Tchadienne (MPFT) directed by M. Brunet (UMR CNRS 6046,

Laboratoire de Géobiologie, Biochronologie et Paléontologie Humaine, Université de Poitiers). Additional support was provided by the Fondation Fyssen for a postdoctoral fellowship.

I gratefully thank the heads and other workers of the following institutions. For the fossil material: Université de Ndjamena and Centre National d'Appui à la Recherche (CNAR, Ndjamena, Chad); Museum National of Ethiopia (MNE, Addis Ababa, Ethiopia); National Museums of Kenya (NMK, Nairobi, Kenya); and Natural History Museum (NHM, London, UK). For the extant material: Museum für Naturkunde (Berlin, Germany); Natural History Museum, Berne (Switzerland); Forschungsinstitut und Naturmuseum Senckenberg (Frankfurt am Main, Germany); Muséum d'Histoire Naturelle de Fribourg (Switzerland); Muséum d'Histoire Naturelle de la Ville de Genève (Switzerland); Natural History Museum (London, UK), Musée Guimet d'Histoire Naturelle (Lyon, France); Muséum National d'Histoire Naturelle (Paris, France); and Musée Royal d'Afrique Centrale (Tervuren, Belgium). I am gratefully indebted to M. Brunet (UMR CNRS 6046), F. C. Howell (LHES, UC Berkeley), P. Vignaud (UMR CNRS 6046), and T. D. White (LHES, UC Berkeley), as well as two anonymous reviewers, for their help, corrections and comments. I finally offer my appreciation to all members of the MPFT.

REFERENCES

- Aguirre E. 1963.** *Hippopotamus crusafonti* n. sp. del Plioceno inferior de Arenas del Rey (Granada). *Notas y Comunicaciones del Instituto Geologico y Minero de Espana* **69**: 215–230.
- Almaseged Z. 1998.** L'Hominidé Omo-323: sa position phylétique et son environnement dans le cadre de l'évolution des communautés de mammifères du Plio-Pleistocène dans la basse vallée de l'Omo (Ethiopie). Unpubl. DPhil thesis, Muséum National d'Histoire Naturelle, Paris.
- Arambourg C. 1944.** Les Hippopotames fossiles d'Afrique. *Comptes Rendus de l'Académie des Sciences Paris* **218**: 602–604.
- Arambourg C. 1947.** *Mission Scientifique de l'Omo 1932–33, Tome I, Géologie – Anthropologie, fasc. 3*. Paris: Editions du Muséum, 314–364.
- Barry JC, Morgan MLE, Flynn LJ, Pilbeam D, Behrensmeyer AK, Raza SM, Khan IA, Badgley C, Hicks J, Kelley J. 2002.** Faunal and environmental change in the late Miocene Siwaliks of northern Pakistan. *Palaeobiology* **28**(2): 1–71.
- Boaz NT. 1990.** The Semliki Research Expedition: history of investigation, results, and background to interpretation. In: Boaz NT, ed. *Evolution of environments and Hominidae in the African Western Rift Valley*. Martinsville, VA: Virginia Museum of Natural History, 3–14.

- Boaz NT. 1994.** Significance of the Western rift for hominid evolution. In: Corruccini RL, Ciochon RL, eds. *Integrative paths to the past: paleoanthropological advances in honor of F. Clark Howell*. Englewoods Cliffs, NJ: Prentice Hall, 321–343.
- Boekschoten GJ, Sondaar PY. 1972.** On the fossil Mammalia of Cyprus. *Proceedings of the Koninklijke Nederlandse Akademie Van Wetenschappen* **B75**(4): 306–338.
- Boisserie JR, Brunet M, Likius A, Vignaud P. 2003.** Hippopotamids from the Djurab Pliocene faunas, Chad, Central Africa. *Journal of African Earth Sciences* **36**(1–2): 15–27.
- Boisserie JR, White TD. 2004.** A new species of Pliocene Hippopotamidae from the Middle Awash, Ethiopia. *Journal of Vertebrate Paleontology* **24**(2): 464–473.
- Brunet M, MPFT. 2000.** Chad: discovery of a vertebrate fauna close to the Mio–Pliocene boundary. *Journal of Vertebrate Paleontology* **20**(1): 205–209.
- Brunet M, Beauvilain A, Geraads D, Guy F, Kasser M, Mackaye HT, Maclatchy LM, Mouchelin G, Sudre J, Vignaud P. 1998.** Tchad: découverte d'une faune de Mammifères du Pliocène inférieur. *Comptes Rendus de l'Académie des Sciences Paris* **326**(2a): 153–158.
- Colbert EH. 1935.** Siwalik mammals in the American Museum of Natural History. *Transactions of the American Philosophical Society* **26**: 278–294.
- Colbert EH. 1938.** Fossil mammals from Burma in the American Museum of Natural History. *Bulletin of the American Museum of Natural History* **74**: 255–436.
- Cooke HBS. 1985.** Plio–Pleistocene Suidae in relation to African hominid deposits. In: Beden M, Berhensmeyer AK, Boaz NT, Bonnefille R, Brain CK, Cooke HBS, Coppens Y, Dechamps R, Eisenmann V, Gentry AW, Geraads D, Gèze R, Guérin C, Harris MJ, Koeniguer J, Letouzey F, Petter G, Vincens A, Vrba ES, eds. *L'environnement des hominidés au Plio–Pléistocène*. Paris: Fondation Singer–Polignac/Masson, 101–117.
- Cooke HBS, Coryndon SC. 1970.** Pleistocene mammals from the Kaiso formation and other related deposits in Uganda. In: Leakey LBS, Savage RJG, eds. *Fossil vertebrates of Africa 2*. London: Academic Press, 147–198.
- Coombs WP, Coombs MJ. 1977.** The origin of anthracotheres. *Neues Jahrbuch für Geologie und Paläontologie, Monatshefte* **10**: 584–599.
- Corbet GB. 1969.** The taxonomic status of the Pygmy hippopotamus, *Choeropsis liberiensis*, from the Niger Delta. *Journal of Zoology* **158**: 387–394.
- Coryndon SC. 1967.** *Hexaprotodont Hippopotamidae of East Africa and the phylogeny of the family*. Dakar: Actes du 7^e Congrès Panafricain de Préhistoire, 350–352.
- Coryndon SC. 1970.** The extent of variation in Fossil Hippopotamus from Africa. *Symposium of the Zoological Society of London* **26**: 135–147.
- Coryndon SC. 1971.** Evolutionary trends in East African Hippopotamidae. *Bulletin de l'Association Française des Etudes sur le Quaternaire* **1**(4): 473–478.
- Coryndon SC. 1976.** Fossil Hippopotamidae from Plio–Pleistocene successions of the Rudolf Basin. In: Coppens Y, Howell FC, Isaac GL, Leakey REF, eds. *Earliest man and environments in the Lake Rudolf Basin*. Chicago: University of Chicago Press, 238–250.
- Coryndon SC. 1977.** The taxonomy and nomenclature of the Hippopotamidae (Mammalia, Artiodactyla) and a description of two new fossil species. *Proceedings of the Koninklijke Nederlandse Akademie van Wetenschappen* **B80**(2): 61–88.
- Coryndon SC. 1978.** Hippopotamidae. In: Maglio VJ, Cooke HBS, eds. *Evolution of African mammals*. Cambridge, MA: Harvard University Press, 483–495.
- Coryndon SC, Coppens Y. 1975.** Une espèce nouvelle d'Hippopotame nain du Plio–Pléistocène du bassin du lac Rodolphe (Ethiopie, Kenya). *Comptes Rendus de l'Académie des Sciences Paris* **280**(D): 1777–1780.
- Crusafont M, Adrover R, Golpe JM. 1964.** Découverte dans le Pikermien d'Espagne du plus primitif des Hippopotames: *Hippopotamus (Hexaprotodon) primaevus* n. sp. *Comptes Rendus de l'Académie des Sciences, Paris* **258**(9): 1572–1575.
- Dietrich WO. 1928.** Pleistocäne Deutsch–Ostafrikanische Hippopotamus–reste. *Wissenschaftliche Ergebnisse des Oldoway Expedition Herausgeben Von Prof. Dr. Reck* **3**: 3–41.
- Ditchfield P, Hicks J, Plummer T, Bishop LC, Potts R. 1999.** Current research on the late Pliocene and Pleistocene deposits north of Homa Mountain, southwestern Kenya. *Journal of Human Evolution* **36**: 123–150.
- Ducrocq S. 1997.** The anthracotheriid genus *Bothriogenys* (Mammalia, Artiodactyla) in Africa and Asia during the Paleogene: phylogenetical and paleobiogeographical relationships. *Stuttgarter Beiträge Naturkunde* **250**: 1–44.
- Eltringham SK. 1993.** The pygmy hippopotamus (*Hexaprotodon liberiensis*). In: Oliver WLR, eds. *Pigs, peccaries and hippos*. Gland: IUCN, 55–60.
- Eltringham SK. 1999.** *The hippos*. Cambridge: Cambridge University Press.
- Erdbrink D, Krommenhoek W. 1975.** Contribution to the knowledge of the fossil Hippopotamidae from the Kazinga Channel area (Uganda). *Säugetierkundliche Mitteilungen* **23**: 258–294.
- Falconer H, Cautley PT. 1836.** Note on the fossil hippopotamus of the Siwalik Hills. *Asiatic Research Calcutta* **19**(3): 39–53.
- Falconer H, Cautley PT. 1847.** *Fauna Antiqua Sivalensis*. London: Smith, Elder and Co.
- Faure M. 1983.** Les Hippopotamidae (Mammalia, Artiodactyla) d'Europe occidentale. Unpubl. DPhil thesis, Université Claude Bernard – Lyon I.
- Faure M. 1984.** *Hippopotamus incognitus* nov. sp., un hippopotame (Mammalia, Artiodactyla) du Pléistocène d'Europe occidentale *Géobios* **17**(4): 427–434.
- Faure M. 1986.** Les Hippopotamidés du Pléistocène ancien d'Oubeidiyeh (Israël). *Mémoires et Travaux du Centre de Recherche Français de Jérusalem* **5**: 107–142.
- Faure M. 1994.** Les Hippopotamidae (Mammalia, Artiodactyla) du rift occidental (bassin du lac Albert, Ouganda).

- Etude Préliminaire. In: Senut B, Pickford M, eds. *Geology and paleobiology of the Albertine Rift Valley, Uganda–Zaire, II: paleobiology*. Orléans: CIFEG, 321–337.
- Faure M, Guérin C. 1990.** *Hippopotamus laloumena* nov. sp., la troisième espèce d'hippopotame holocène de Madagascar. *Comptes Rendus de l'Académie des Sciences Paris* **310**(2): 1299–1305.
- Feibel CS, Brown FH, McDougall I. 1989.** Stratigraphic context of fossil Hominids from the Omo group deposits. Northern Turkana Basin, Kenya and Ethiopia. *American Journal of Physical Anthropology* **78**: 595–622.
- Gatesy J. 1998.** Molecular evidence for the phylogenetic affinities of Cetacea. In: Thewissen JGM, ed. *The emergence of whales*. New York: Plenum Press, 63–111.
- Gaudry A. 1876.** Sur un Hippopotame fossile découvert à Bone (Algérie). *Bulletin de la Société Géologique de France* **3**(4): 147–154.
- Gaziry AW. 1987.** *Hexaprotodon sahabiensis* (Artiodactyla, Mammalia): a new hippopotamus from Libya. In: Boaz NT, El-Arnauti A, Gaziry AW, de Heinzelin J, Boaz DD, eds. *Neogene paleontology and geology of Sahabi*. New York: Alan R. Liss, 303–315.
- Geisler JH. 2001.** New morphological evidence for the phylogeny of Artiodactyla, Cetacea, and Mesonychidae. *American Museum Novitates* **40**: 1–53.
- Gentry AW. 1999.** A fossil hippopotamus from the Emirate of Abu Dhabi, United Arab Emirates. In: Whybrow PJ, Hill A, eds. *Fossil vertebrates of Arabia*. New Haven, CT: Yale University Press, 271–289.
- Gentry AW, Hooker JJ. 1988.** The phylogeny of the Artiodactyla. In: Benton MJ, ed. *The phylogeny and classification of the tetrapods 2: mammals*. Oxford: Clarendon Press, 235–272.
- Geraads D. 1980.** La faune des sites à 'Homo erectus' des carrières Thomas (Casablanca, Maroc). *Quaternaria* **22**: 65–94.
- Geraads D. 1989.** Vertébrés du Miocène supérieur du Djebel Krechem el Artsouma (Tunisie centrale). Comparaisons biostratigraphiques. *Géobios* **22**(6): 777–801.
- Gèze R. 1980.** Les Hippopotamidae (Mammalia, Artiodactyla) du Plio–Pléistocène de l'Éthiopie. Unpubl. DPhil thesis, Université Pierre et Marie Curie – Paris VI.
- Gèze R. 1985.** Répartition paléocéologique et relations phylogénétiques des Hippopotamidae (Mammalia, Artiodactyla) du Néogène d'Afrique Orientale. In: Beden M, Behrensmeyer AK, Boaz NT, Bonnefille R, Brain CK, Cooke HBS, Coppins Y, Dechamps R, Eisenmann V, Gentry AW, Geraads D, Gèze R, Guérin C, Harris MJ, Koeniguer J, Letouzey F, Peter G, Vincens A, Vrba ES, eds. *L'environnement des hominidés au Plio–Pléistocène*. Paris: Fondation Singer–Polignac/Masson, 81–100.
- Gingerich PDUI, Haq M, Zalmout IS, Hussain Khan I, Malkani MS. 2001.** Origin of whales from early artiodactyls: hand and feet of Eocene Protocetidae from Pakistan. *Science* **293**: 2239–2242.
- Harris JM. 1991.** Family Hippopotamidae. In: Harris JM, ed. *Koobi Fora research project 3. The fossil ungulates*. Oxford: Clarendon Press, 31–85.
- Harris JM, Brown FH, Leakey MG. 1988.** Stratigraphy and paleontology of Pliocene and Pleistocene localities west of Lake Turkana, Kenya. *Contributions in Science* **399**: 1–128.
- Harris JM, White TD. 1979.** Evolution of the Plio–Pleistocene African Suidae. *Transactions of the American Philosophical Society* **69**(2): 1–128.
- Harrison T. 1997.** The anatomy, paleobiology, and phylogenetic relationships of the Hippopotamidae (Mammalia, Artiodactyla) from the Manonga Valley, Tanzania. In: Harrison T, ed. *Neogene paleontology of the Manonga Valley, Tanzania*. New York: Plenum Press, 137–190.
- Holroyd PA, Ciochon RL. 1994.** Relative ages of Eocene primate-bearing deposits of Asia. In: Fleagle JG, Kay RF, eds. *Anthropoid origins*. New York: Plenum Press, 123–141.
- Hooijer DA. 1946.** Notes on some Pontian mammals from Sicily figured by Seguenza. *Archives Néerlandaises de Zoologie* **7**: 301–333.
- Hooijer DA. 1950.** The fossil Hippopotamidae of Asia, with notes on the recent species. *Zoologische Verhandelingen* **8**: 1–123.
- Hopwood AT. 1926.** Some Mammalia from the Pliocene of Homa Mountain, Victoria Nyanza. *Annals and Magazine of Natural History* **9**(18): 266–272.
- Houtekamer JL, Sondaar PY. 1979.** Osteology of the fore limb of the Pleistocene dwarf hippopotamus from Cyprus with special reference to phylogeny and function. *Proceedings of the Koninklijke Nederlandse Akademie van Wetenschappen* **B82**(4): 411–448.
- Joleaud L. 1920.** Contribution à l'étude des Hippopotames fossiles. *Bulletin de la Société Géologique de France* **22**: 13–26.
- Kahlke RD. 1990.** Zum stand der Erforschung fossiler Hippopotamiden (Mammalia, Artiodactyla). Eine übersicht. *Quartärpaläontologie* **8**: 107–118.
- Kent PE. 1942.** The Pleistocene beds of Kanam and Kanjera, Kavirondo, Kenya. *Geological Magazine* **79**: 117–132.
- Lacomba JI, Morales J, Robles F, Santisteban C, Alberdi MT. 1986.** Sedimentología y paleontología del yacimiento finimioceno de La Portera (Valencia). *Estudios Geológicos* **42**: 167–180.
- Lange D. 1989.** Préliminaires pour un histoire des Sao. *The Journal of African History* **30**(2): 189–210.
- Laws RW. 1968.** Dentition and ageing of the hippopotamus. *East African Wildlife Journal* **6**: 19–52.
- Leakey MG, Feibel CS, Bernor RL, Harris JM, Cerling TE, Stewart KM, Storrs GW, Walker A, Werdelin L, Winkler AJ. 1996.** Lothagam: a record of faunal change in the late Miocene of East Africa. *Journal of Vertebrate Paleontology* **16**(3): 556–570.
- Leidy J. 1853.** On the osteology of the head of *Hippopotamus*. *Journal of the Academy of Natural Sciences of Philadelphia* **2**: 207–224.
- Lydekker R. 1884.** Indian Tertiary and post-Tertiary Vertebrata: Siwalik and Narbaba bunodont Suina. *Palaeontologica Indica* **10–3**(2): 35–104.
- van der Made J. 1999.** Superfamily Hippopotamoidea. In: Rössner GE, Heissig K, eds. *The Miocene land mammals of Europe*. Munich: Verlag Dr Friedrich Pfeil, 203–208.

- Matthew WD. 1929.** Reclassification of the Artiodactyl families. *Bulletin of the Geological Society of America* **40**: 403–408.
- Mazin JM, de Buffrénil V. 1998.** What is an aquatic tetrapod? Some introductory remarks. In: Mazin JM, de Buffrénil V, eds. *Secondary adaptation of tetrapods to life in water*. Munich: Verlag Dr Friedrich Pfeil. 91–94.
- Mazza P. 1991.** Interrelations between Pleistocene hippopotami of Europe and Africa. *Bolletino della Società Paleontologica Italiana* **30**(2): 153–186.
- Mazza P. 1995.** New evidence on the Pleistocene hippopotamuses of Western Europe. *Geologica Romana* **31**: 61–241.
- Misonne X. 1952.** Quelques éléments nouveaux concernant *Hippopotamus imaguncula* Hopwood. *Bulletin de l'Institut Royal des Sciences Naturelles de Belgique* **28**(3): 1–12.
- Morton SG. 1844.** On a supposed new species of hippopotamus. *Proceedings of the Academy of Natural Sciences of Philadelphia* **2**(1): 14–17.
- Naylor GJP, Adams DC. 2001.** Are the fossil data really at odds with the molecular data? Morphological evidence for Cetartiodactyla phylogeny reexamined. *Systematic Biology* **50**(3): 444–453.
- Nikaido M, Rooney AP, Okada N. 1999.** Phylogenetic relationships among cetartiodactyls based on insertions of short and long interspersed elements: hippopotamuses are the closest extant relatives of whales. *Proceedings of the National Academy of Sciences, USA* **96**: 10,261–10,266.
- O'Leary MA, Geisler JH. 1999.** The position of Cetacea within Mammalia: phylogenetic analysis of morphological data from extinct and extant taxa. *Systematic Biology* **48**: 455–490.
- Owen R. 1845.** *Odontography*. London.
- Pavlakakis PP. 1990.** Plio–Pleistocene Hippopotamidae from the Upper Semliki. In: Boaz NT, ed. *Results from the Semliki Research Expedition*. Martinsville, VA: Virginia Museum of Natural History, 203–223.
- Pearson HG. 1927.** On the skulls of early Tertiary Suidae, together with an account to the otic region in some other primitive Artiodactyls. *Philosophical Transactions of the Royal Society of London B* **215**: 389–460.
- Pickford M. 1983.** On the origins of Hippopotamidae together with descriptions of two species, a new genus and a new subfamily from the Miocene of Kenya. *Géobios* **16**(2): 193–217.
- Pickford M. 1991.** Revision of the Neogene Anthracotheriidae of Africa. *The Geology of Libya* **4**: 1491–1525.
- Pickford M. 1993.** Old World Suoid systematics, phylogeny, biogeography and biostratigraphy. *Palaeontologia i Evolucio* **26–27**: 237–269.
- Pilgrim GE. 1928.** Some newly discovered Eocene mammals from Burma. *Records of the Geological Survey of India* **47**: 42–77.
- Pilgrim GE, de Cotter GP. 1916.** The Artiodactyla from the Eocene of Burma. *Palaeontologica Indica* **13**: 1–16.
- Sondaar PY. 1977.** Insularity and its effect on Mammal evolution. In: Hecht MK, Goody PC, Hecht BM, eds. *Major patterns in vertebrate evolution*. New York: Plenum, 671–707.
- Stuenes S. 1981.** On the bi-rooted upper first premolar in some specimens of the Madagascan Holocene Hippopotamidae. *Bulletin of the Geological Institutions of the University of Uppsala NS9*: 29–32.
- Stuenes S. 1989.** Taxonomy, habits, and relationships of the subfossil Madagascan Hippopotami *Hippopotamus lemerlei* and *H. madagascariensis*. *Journal of Vertebrate Paleontology* **9**(3): 241–268.
- Sudre J. 1978.** Les artiodactyles de l'Eocène moyen et supérieur d'Europe occidentale (systématique et évolution). *Mémoires et Travaux de l'Ecole Pratique des Hautes Etudes, Institut de Montpellier* **7**: 1–229.
- Swofford DL. 1998.** *PAUP*: phylogenetic analysis using parsimony (*and other methods), v.4*. Sunderland, MA: Sinauer Associates.
- Thewissen JGM, Williams EM, Roe LJ, Hussain ST. 2001.** Skeletons of terrestrial cetaceans and the relationship of whales to artiodactyls. *Nature* **413**: 277–281.
- Ursing BM, Arnason U. 1998.** Analyses of mitochondrial genomes strongly support a hippopotamus–whale clade. *Proceedings of the Royal Society of London B* **265**: 2251–2255.
- Vekua A. 1986.** The lower Pleistocene mammalian fauna of Akhalkalaki (Southern Georgia, USSR). *Palaeontographia Italica* **74**: 63–96.
- Vignaud P, Düringer P, Mackaye HT, Likies A, Blondel C, Boisserie JR, de Bonis L, Eisenmann V, Etienne ME, Geraads D, Guy F, Lehmann T, Lihoreau F, Lopez-Martinez N, Mourer-Chauviré C, Otero O, Rage JC, Schuster M, Viriot L, Zazzo A, Brunet M. 2002.** Geology and palaeontology of the Upper Miocene Toros-Menalla hominid locality, Chad. *Nature* **418**: 152–155.
- Weston EM. 1997.** A biometrical analysis of evolutionary change within the Hippopotamidae. Unpubl. DPhil thesis, University of Cambridge.
- Weston EM. 2000.** A new species of Hippopotamus *Hexaprotodon lothagamensis* (Mammalia: Hippopotamidae) from the late Miocene of Kenya. *Journal of Vertebrate Paleontology* **20**(1): 177–185.
- Weston EM. 2003.** Fossil Hippopotamidae from Lothagam. In: Leakey MG, Harris JM, eds. *Lothagam, the dawn of humanity in Eastern Africa*. New York: Columbia University Press, 441–483.

APPENDIX

THE CHARACTERS: DESCRIPTION AND COMMENTS

Skull (Figs 2, 3)

1. *Post-canine constriction of the muzzle (Fig. 2)*: (0) weak constriction in comparison to the lateral extension of the skull canine apophyses; (1) deep constriction in comparison to the lateral extension of the skull canine apophyses. On the skull, post-canine constrictions can be easily grouped in two clusters: the weak constrictions are observed in species considered as poorly advanced (e.g. *Hex. harvardi*, *Hex. liberiensis*, Chadian Pliocene forms). This character cannot be extended to the

mandible because sexual dimorphism is probably responsible for the larger range of variation observed for most species.

2. *Inter-premaxillae suture* (Fig. 2): (0) complete; (1) partial, a gap occurs between the premaxillae anteriorly. A complete suture has been frequently cited in the diagnosis of *Hexaprotodon*. In fact, it appears to be partial for most of the African Plio-Pleistocene species placed in this genus.
3. *Facial crest morphology (ventral or dorsal view)* (Fig. 2): (0) regularly convex, gradually sloping postero-laterally from the zygomatic arch toward the maxilla; (1) with an obvious angle or a well-developed facial tubercle at anterior edge of orbit, and linked with an abrupt change of direction in the facial crest.
4. *Zygomatic arch (ventral or dorsal view)* (Fig. 2): (0) gracile, strongly medio-laterally compressed; (1) robust, medio-laterally thick.
5. *Bone contact in the lachrymal area* (Fig. 2): (0) lachrymal bone always separated from the nasal bone by a maxillary process of the frontal bone; (1) lachrymal narrowly contacts the nasal bone, forming a quadruple junction between the nasal, frontal, lachrymal and maxillary bones, or variations around this conformation; (2) lachrymal always in contact with the nasal for some length, isolating the frontal and maxillary bones. This feature, on which Coryndon (1977) defined the separation between *Hexaprotodon* and *Hippopotamus*, is seen in an intermediate state (state 1) in *Hex. protamphibius* and *Hex. karumensis*. Moreover, Gèze (1985) described a particular organization of the lachrymal area for the genus he created: *Trilobophorus*. The examination of the material revealed that the concerned specimens present a lachrymal not very different of that known for *Hippopotamus* (state 2).
6. *Lachrymal shape* (Fig. 2): (0) quadrangular bone of rather constant width, widely participating in the anterior border of the orbit; (1) narrow at the anterior border of the orbit, and exposed over a large surface of the face, more or less circular in shape.
7. *Relative position of the anterior border of the orbit (in lateral view)* (Fig. 3): (0) anterior to the middle of M2/ (1) at the level or posterior to the middle of M2/.
8. *Size of the orbits* (Fig. 3): (0) small relative to the length of the face; (1) large relative to the face.
9. *Height of the orbits* (Fig. 3): (0) orbital summit below the cranial roof; (1) orbital summit at the level of the cranial roof; (2) orbital summit elevated well above the cranial roof.
10. *Notch on the anterior border of the orbit* (Fig. 3): (0) absent; (1) weak; (2) deep and widely open; (3) deep and narrow.
11. *Profile of the cranial roof anterior to the orbits (in lateral view)* (Fig. 3): (0) flat; (1) angulated, with angle just anterior to orbits.
12. *Sagittal crest morphology* (Fig. 3): (0) crest compressed transversally (laminar) and very elevated posteriorly above the braincase; (1) large crest, strongly sloping up posteriorly; (2) the same, but horizontal or slightly sloping up posteriorly; (3) the same, but sloping down posteriorly.
13. *Development of the supra-orbital processes* (Fig. 3): (0) weak; (1) well-developed laterally.
14. *Braincase morphology (dorsal view)* (Fig. 3): (0) elongated, rounded transversal section, with a weak postorbital constriction; (1) elongated, transversally compressed (triangular transversal section); (2) short and globular, with a well-marked postorbital constriction.
15. *Orientation of the posterior border of the glenoid process (in ventral view)* (Fig. 2): (0) parallel or slightly divergent from the exoccipital; (1) strongly frontward divergent from the exoccipital.
16. *Outline of the glenoid articular area (in ventral view)* (Fig. 2): (0) small, globular and well delimited; (1) large with diffuse borders, with an elongated shape (anterior and posterior border more or less rectilinear and laterally converging); (2) large with diffuse borders, with a complex shape (anterior and posterior borders not rectilinear and/or not symmetrical).
17. *Morphology of the tympanic bulla* (Fig. 2): (0) bulla large and elongated, with a rounded apex and, anteriorly, a reduced or absent muscular process for the tensor veli palatini muscle; (1) globular bulla with a developed muscular process; (2) bulla small and compressed, with well developed muscular process and keel.

Mandible (Fig. 4)

18. *Orientation of the symphysis plane (in lateral view)*: (0) almost horizontal; (1) anterodorsally inclined.
19. *Transition between the frontal and ventral faces of the symphysis*: (0) gentle angle; (1) abrupt angle.
20. *Incisor alveolar process*: (0) continuous between the two canines, forming an overhang relative to the frontal face of the symphysis; (1) weakly overhanging, generally interrupted between the first incisors.
21. *Position of the canine relative to the incisor row (in dorsal view)*: (0) anterior border of the canine alveolus at the level of the incisor alveoli or posterior; (1) anterior border of the canine alveolus anterior to the incisor alveoli; (2) posterior border of the canine alveolus anterior to the incisor alveoli.
22. *Canine processes (in dorsal view)*: (0) poorly developed; (1) developed.

23. *I/1-I/1 diastema*: (0) shorter than the mesio-distal diameter of the I/1; (1) longer than the mesio-distal diameter of the I/1
24. *Gonial angle*: (0) poorly developed; (1) well-developed, but not hook-shaped; (2) well-developed, hook-shaped.
25. *Lateral expansion of the gonial angle (in dorsal view)*: (0) not warped laterally away from the corpus direction; (1) laterally warped.

Dentition (Fig. 5)

In mammal phylogeny, the cheek tooth rows often play a crucial role. For the Suiformes, the phylogeny of several families has been largely inferred from the study of dental remains (see, for example, Coombs & Coombs, 1977; Sudre, 1978; Harris & White, 1979). As Coryndon noted in 1977 (p. 63), it is not the case for the Hippopotamidae: 'It is unfortunate that, as far as hippopotamids are concerned, molar teeth are very conservative in development and are possibly the least useful element for diagnosis, slight variation in enamel pattern often reflecting slight differences in feeding habits rather than morphogenetic characters'. In fact, hippo cheek teeth show only minor variations, and these variations can be found in most of the known species. The general molar organization has been preserved since the late Miocene. Therefore, in this analysis, only five characters of the 37 are cheek tooth characters, and only one concerns the molar dentition (character 37).

26. *Upper incisor number*: (0) six; (1) four.
27. *Posterior groove of the upper canines*: (0) absent; (1) shallow and narrow (canine with an almost rounded section); (2) shallow and wide (bilobate section); (3) deep (bilobate section). The shape and ornamentation of the canines have been more frequently used for generic identification than the morphology of the lachrymal area (see also character 34). In the literature (e.g. Coryndon, 1977; Gèze, 1980; Harris, 1991; Harrison, 1997), a deep posterior groove on the upper canine is regarded as a diagnostic character of *Hexaprotodon*. However, within this genus, different conditions can be observed for this multistate character. For example, state 2 is expressed in *Hex. bruneti* from Middle Awash, Ethiopia (Boissérie & White, 2004).
28. *Shape of the P1/alveolus*: (0) large, transversally pinched; (1) most frequently small and rounded, or absent. The state 1 probably corresponds to the loss of dp1/replacement. The pinched shape in state 0 is linked to the existence of two roots or of two pulp canals just below the cervix (in most

instances, it is not possible to observe the roots directly). Stuenes (1981, 1989) denied any phylogenetic significance to this feature on the basis of the occasional appearance of bi-rooted P1/s in the Madagascan hippopotamuses. However, this states show relative frequencies that are very different between species. The state 0 may rarely appear in some species (e.g. in modern hippos, where a pinched alveolus is present in about 6% of the observed specimens). But generally, these species do not exhibit the double-rooted P1/s that are very frequent in *Hex. harvardi* and *Hex. sivalensis*. These different frequencies have more probably a phylogenetic significance, and it is therefore retained here contra Stuenes (1981, 1989).

29. *Disto-lingual heel for P2/and P3/*: (0) reduced or absent on both teeth; (1) strong at least on the P3/.
30. *P4/morphology*: (0) bicuspidate, the two cusps being subequal in size; (1) bicuspidate tooth with unequal cusps, or single-cuspidate tooth.
31. *Lower incisor number*: (0) six; (1) four; (2) two.
32. *Size of the I/3 relative to the I/1*: (0) subequal; (1) smaller or absent; (2) larger.
33. *Relative position of the lower incisors (in frontal view)*: (0) not horizontally aligned; (1) horizontally aligned.
34. *Enamel ornamentation of the lower canines*: (0) smooth or with small to strong ridges, these ridges being always parallel; (1) strong and convergent ridges. The state 1 is generally regarded as an important *Hippopotamus* apomorphy.
35. *Anterior relation between the lower cheek tooth rows (in dorsal view)*: (0) subparallel or slightly convergent; (1) divergent.
36. *P/4 morphology*: (0) presence of a large centro-lingual accessory cuspid, with one or several other accessory cuspids in distal position; (1) lingual accessory cuspid distally shifted, low and reduced, or absent, often with no distal accessory cuspids.
37. *Molar hypsodonty*: (0) low-crowned teeth, with an hypsodonty index (height of the crown \times 100/buccolingual breadth of the crown) inferior or equal to 125 (lower molars) or 100 (upper molars); (1) high-crowned teeth, with an hypsodonty index superior to 125 (lower molars) or 100 (upper molars). For this last character, the definition of the states, not distinguishable on worn teeth, is supported by an obvious difference between the high-crowned teeth observed in *Hippopotamus* and some Asian species on the one hand, and the low-crowned teeth of all other hippopotamids on the other hand.